

< High-power GaAs FET (small signal gain stage) >

MGF0913A

L & S BAND / 1.2W
SMD non - matched

DESCRIPTION

The MGF0913A GaAs FET with an N-channel schottky Gate, is designed for use UHF band amplifiers.

FEATURES

- High output power
Po=31dBm(TYP.) @f=1.9GHz,Pin=18dBm
- High power gain
Gp=13dB(TYP.) @f=1.9GHz
- High power added efficiency
ηadd=48%(TYP.) @f=1.9GHz,Pin=18dBm
- Hermetic Package

APPLICATION

- For UHF Band power amplifiers

QUALITY

- GG

RECOMMENDED BIAS CONDITIONS

- Vds=10V • Ids=200mA • Rg=500Ω

Delivery -01:Tape & Reel(1K), -03:Trai(50pcs)

Absolute maximum ratings (Ta=25°C)

Symbol	Parameter	Ratings	Unit
VGSO	Gate to source breakdown voltage	-15	V
VGDO	Gate to drain breakdown voltage	-15	V
ID	Drain current	800	mA
IGR	Reverse gate current	-2.5	mA
IGF	Forward gate current	5.4	mA
PT	Total power dissipation	5.0	W
Tch	Channel temperature	175	°C
Tstg	Storage temperature	-65 to +175	°C

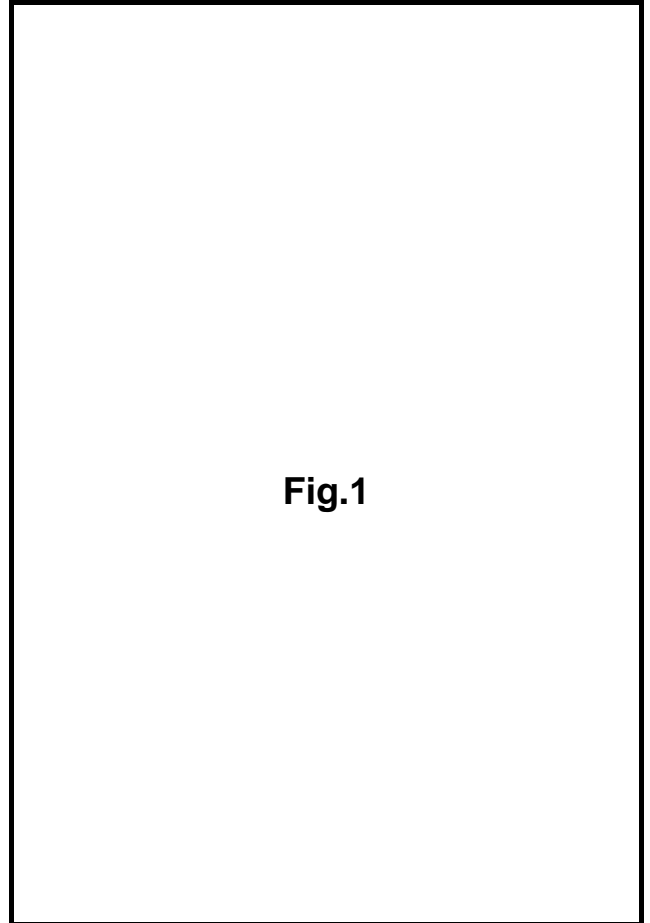

Fig.1

Electrical characteristics (Ta=25°C)

Symbol	Parameter	Test conditions	Limits			Unit
			Min.	Typ.	Max.	
IDSS	Saturated drain current	VDS=3V,VGS=0V	400	550	800	mA
VGS(off)	Gate to source cut-off voltage	VDS=3V,ID=2.5mA	-1	-3	-5	V
gm	Transconductance	VDS=3V,ID=300mA	-	200	-	mS
Po	Output power	VDS=10V,ID=200mA,f=1.9GHz	29.5	31	-	dBm
ηadd	Power added Efficiency	Pin=18dBm	-	48	-	%
GLP	Linear Power Gain	VDS=10V,ID=200mA,f=1.9GHz	11	13	-	dB
NF	Noise figure		-	2.0	-	dB
Rth(ch-c)	Thermal Resistance *1	ΔVf Method	-	20	30	°C/W

*1:Channel to case / Above parameters, ratings, limits are subject to change.

MGF0913A

L & S BAND / 1.2W
SMD non - matched

MGF0913A TYPICAL CHARACTERISTICS

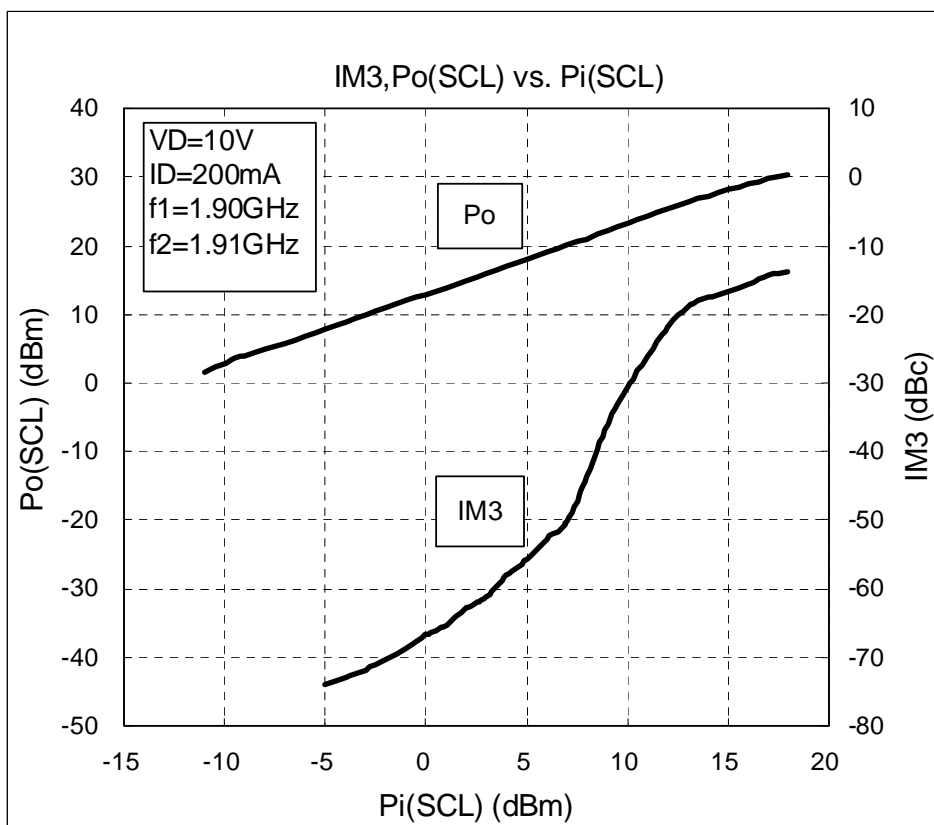
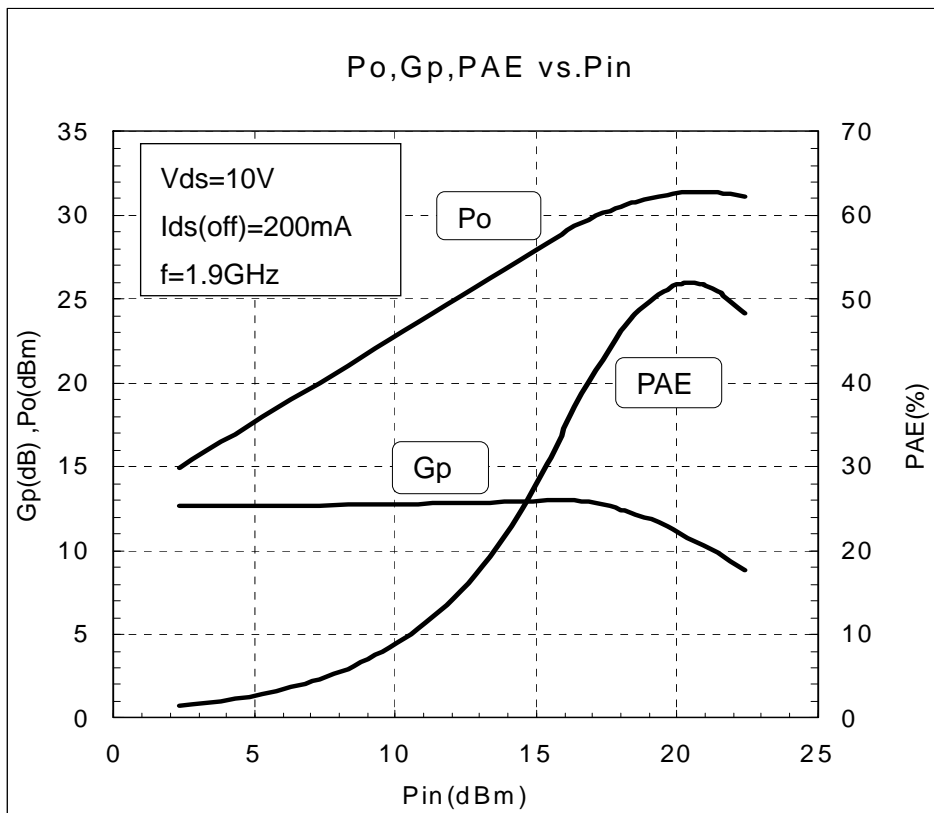

MGF0913A

L & S BAND / 1.2W
SMD non - matched

MGF0913A S PARAMETERS (Ta=25°C,VD=10V,ID=200mA, Reference Plane see Fig.1)

freq. (MHz)	S11		S21		S12		S22		K	MAG/MSG (dB)
	(mag)	(ang)	(mag)	(ang)	(mag)	(ang)	(mag)	(ang)		
600	0.846	-99.11	7.877	113.45	0.032	41.63	0.241	-112.66	0.45	23.91
1000	0.795	-129.78	5.523	91.49	0.038	29.94	0.296	-126.47	0.68	21.62
1400	0.758	-147.40	4.105	74.02	0.043	23.18	0.335	-132.57	0.92	19.80
1800	0.733	-159.19	3.265	59.68	0.046	19.12	0.372	-135.16	1.14	16.26
2200	0.713	-168.29	2.755	47.38	0.049	16.24	0.412	-136.52	1.29	14.27
2600	0.696	-175.89	2.413	36.27	0.053	13.56	0.456	-137.70	1.34	13.08
3000	0.675	177.02	2.150	25.69	0.057	10.50	0.500	-138.96	1.39	12.05
3400	0.648	170.52	1.930	15.19	0.063	6.75	0.537	-140.26	1.41	11.04
3800	0.611	165.48	1.751	4.44	0.070	2.20	0.565	-141.48	1.47	9.91
4200	0.563	159.35	1.626	-6.74	0.079	-3.15	0.582	-142.64	1.53	8.84
4600	0.504	150.60	1.566	-18.46	0.091	-9.28	0.592	-143.97	1.53	8.08
5000	0.437	138.53	1.563	-30.74	0.104	-16.17	0.606	-145.86	1.45	7.78
5400	0.367	123.05	1.571	-43.58	0.118	-23.85	0.614	-148.72	1.38	7.57
5800	0.304	104.53	1.507	-56.94	0.134	-32.41	0.616	-152.68	1.35	6.95
6200	0.260	83.65	1.422	-70.83	0.151	-41.99	0.613	-157.29	1.34	6.26
6600	0.252	61.24	1.370	-85.27	0.168	-52.79	0.599	-160.95	1.30	5.82
7000	0.298	38.21	1.336	-100.37	0.185	-65.01	0.568	-161.71	1.25	5.60
7400	0.376	15.46	1.290	-116.34	0.202	-78.79	0.521	-160.65	1.20	5.32
7800	0.486	-6.26	1.213	-133.51	0.217	-94.17	0.469	-154.18	1.18	4.94
8200	0.622	-26.32	1.103	-152.37	0.227	-110.98	0.444	-141.91	1.13	4.65
8600	0.762	-44.27	0.963	-173.58	0.221	-128.75	0.503	-128.51	1.09	4.60
9000	0.864	-59.90	0.804	167.54	0.201	-146.58	0.605	-122.63	1.06	4.56
9400	0.931	-73.16	0.640	150.86	0.175	-163.02	0.708	-124.22	1.01	5.05
9800	0.969	-84.19	0.487	136.98	0.150	-175.89	0.789	-128.49	0.95	5.11
10200	0.985	-93.24	0.359	125.65	0.129	173.23	0.844	-134.30	0.92	4.45
10600	0.988	-100.63	0.264	116.52	0.112	163.85	0.877	-140.83	0.93	3.72
11000	0.986	-106.66	0.207	109.19	0.099	155.65	0.898	-147.37	0.97	3.20
11400	0.984	-111.48	0.179	103.32	0.089	148.28	0.916	-153.31	0.99	3.03
11800	0.983	-115.02	0.161	98.69	0.080	141.70	0.933	-158.19	1.00	3.04
12200	0.977	-116.79	0.119	95.29	0.071	136.14	0.939	-161.64	1.12	0.17

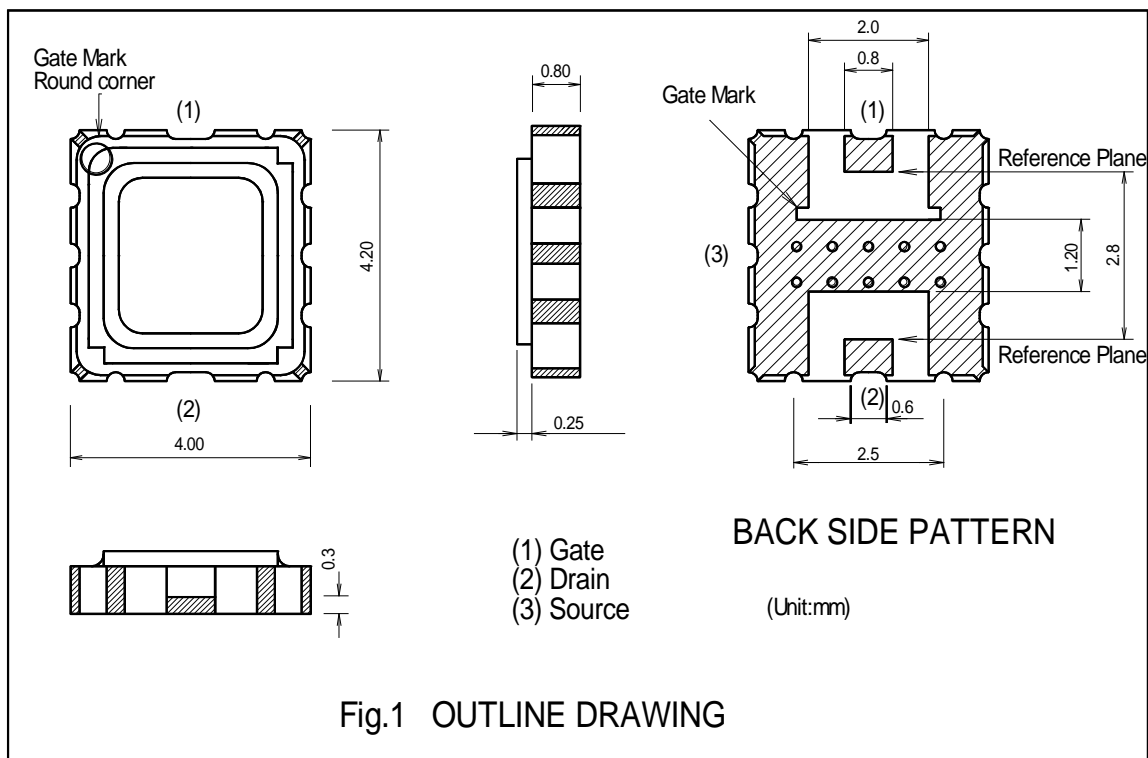

Keep safety first in your circuit designs!

Mitsubishi Electric Corporation puts the maximum effort into making semiconductor products better and more reliable, but there is always the possibility that trouble may occur with them. Trouble with semiconductors may lead to personal injury, fire or property damage. Remember to give due consideration to safety when making your circuit designs, with appropriate measures such as (i) placement of substitutive, auxiliary circuits, (ii) use of non-flammable material or (iii) prevention against any malfunction or mishap.

Notes regarding these materials

- These materials are intended as a reference to assist our customers in the selection of the Mitsubishi semiconductor product best suited to the customer's application; they do not convey any license under any intellectual property rights, or any other rights, belonging to Mitsubishi Electric Corporation or a third party.
- Mitsubishi Electric Corporation assumes no responsibility for any damage, or infringement of any third-party's rights, originating in the use of any product data, diagrams, charts, programs, algorithms, or circuit application examples contained in these materials.
- All information contained in these materials, including product data, diagrams, charts, programs and algorithms represents information on products at the time of publication of these materials, and are subject to change by Mitsubishi Electric Corporation without notice due to product improvements or other reasons. It is therefore recommended that customers contact Mitsubishi Electric Corporation or an authorized Mitsubishi Semiconductor product distributor for the latest product information before purchasing a product listed herein.
The information described here may contain technical inaccuracies or typographical errors. Mitsubishi Electric Corporation assumes no responsibility for any damage, liability, or other loss rising from these inaccuracies or errors.
Please also pay attention to information published by Mitsubishi Electric Corporation by various means, including the Mitsubishi Semiconductor home page (<http://www.MitsubishiElectric.com/>).
- When using any or all of the information contained in these materials, including product data, diagrams, charts, programs, and algorithms, please be sure to evaluate all information as a total system before making a final decision on the applicability of the information and products. Mitsubishi Electric Corporation assumes no responsibility for any damage, liability or other loss resulting from the information contained herein.
- Mitsubishi Electric Corporation semiconductors are not designed or manufactured for use in a device or system that is used under circumstances in which human life is potentially at stake. Please contact Mitsubishi Electric Corporation or an authorized Mitsubishi Semiconductor product distributor when considering the use of a product contained herein for any specific purposes, such as apparatus or systems for transportation, vehicular, medical, aerospace, nuclear, or undersea repeater use.
- The prior written approval of Mitsubishi Electric Corporation is necessary to reprint or reproduce in whole or in part these materials.
- If these products or technologies are subject to the Japanese export control restrictions, they must be exported under a license from the Japanese government and cannot be imported into a country other than the approved destination.
Any diversion or re-export contrary to the export control laws and regulations of Japan and/or the country of destination is prohibited.
- Please contact Mitsubishi Electric Corporation or an authorized Mitsubishi Semiconductor product distributor for further details on these materials or the products contained therein.