

PRELIMINARY
 Notice: This is not a final specification.
 Some parametric limits are subject to change.

MITSUBISHI HVIGBT MODULES CM1500HC-66R

4th-Version HVIGBT (High Voltage Insulated Gate Bipolar Transistor) Modules

**HIGH POWER SWITCHING USE
 INSULATED TYPE**

CM1500HC-66R



- IC 1500 A
- VCES 3300V
- 1-element in a Pack
- Insulated Type
- LPT-IGBT / Soft Recovery Diode
- AISiC Baseplate

APPLICATION

Traction drives, High Reliability Converters / Inverters, DC choppers

OUTLINE DRAWING & CIRCUIT DIAGRAM

Dimensions in mm

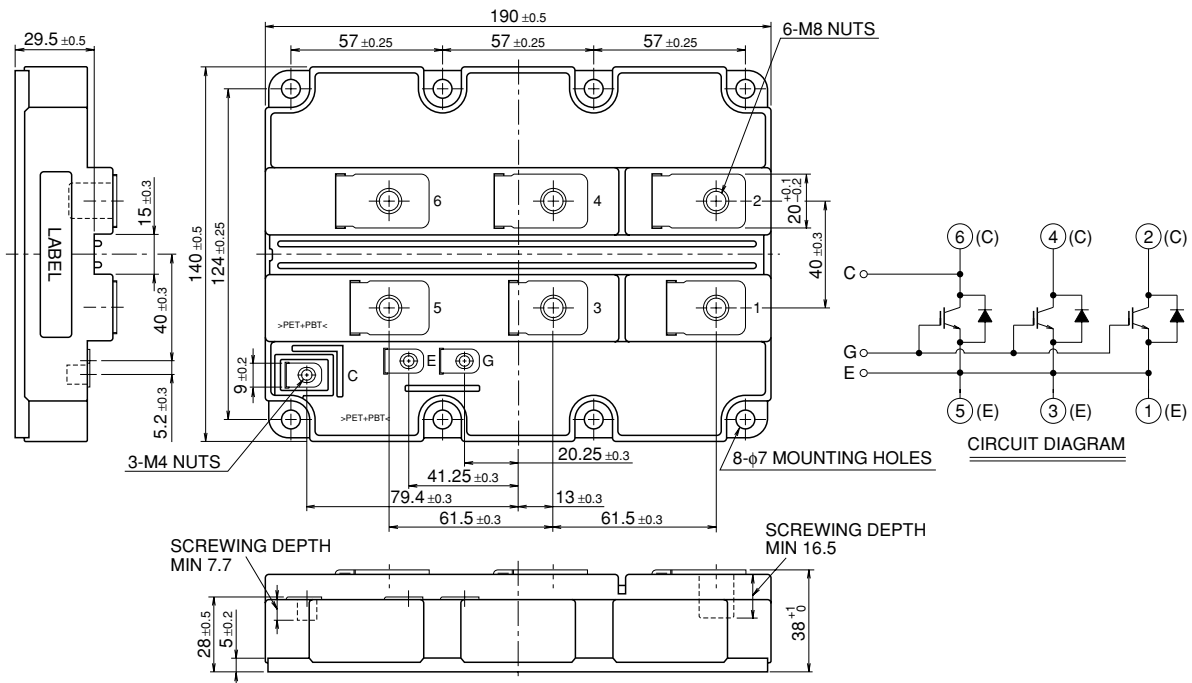

HVIGBT (High Voltage Insulated Gate Bipolar Transistor) Modules

Mar. 2009

CM1500HC-66R

**HIGH POWER SWITCHING USE
 INSULATED TYPE**

4th-Version HVIGBT (High Voltage Insulated Gate Bipolar Transistor) Modules

MAXIMUM RATINGS

Symbol	Item	Conditions	Ratings	Unit
VCES	Collector-emitter voltage	VGE = 0V, Tj = -40...+150°C	3300	V
		VGE = 0V, Tj = -50°C	3200	
VGES	Gate-emitter voltage	VCE = 0V, Tj = 25°C	± 20	V
IC	Collector current	DC, Tc = 95°C	1500	A
ICM		Pulse (Note 1)	3000	A
IE	Emitter current (Note 2)	DC	1500	A
IEM		Pulse (Note 1)	3000	A
Pc	Maximum power dissipation(Note 3)	Tc = 25°C, IGBT part	15600	W
Viso	Isolation voltage	RMS, sinusoidal, f = 60Hz, t = 1 min.	6000	V
Ve	Partial discharge extinction voltage	RMS, sinusoidal, f = 60Hz, QPD ≤ 10 pC	2600	V
Tj	Junction temperature		-50 ~ +150	°C
Top	Operating temperature		-50 ~ +150	°C
Tstg	Storage temperature		-55 ~ +150	°C
tpsc	Maximum short circuit pulse width	VCC = 2500V, VCE ≤ VCES, VGE = 15V, Tj = 150°C	10	μs

ELECTRICAL CHARACTERISTICS

Symbol	Item	Conditions	Limits			Unit	
			Min	Typ	Max		
ICES	Collector cutoff current	VCE = VCES, VGE = 0V	Tj = 25°C	—	—	6.0	mA
			Tj = 125°C	—	6.0	—	
			Tj = 150°C	—	36.0	—	
VGE(th)	Gate-emitter threshold voltage	VCE = 10 V, IC = 150 mA, Tj = 25°C	5.7	6.2	6.7	V	
IGES	Gate leakage current	VGE = VGES, VCE = 0V, Tj = 25°C	-0.5	—	0.5	μA	
Cies	Input capacitance	VCE = 10 V, VGE = 0 V, f = 100 kHz Tj = 25°C	—	210.0	—	nF	
Coes	Output capacitance		—	13.0	—	nF	
Cres	Reverse transfer capacitance		—	6.0	—	nF	
Qg	Total gate charge	VCC = 1800 V, IC = 1500 A, VGE = ±15 V	—	16.0	—	μC	
VCE(sat)	Collector-emitter saturation voltage	IC = 1500 A (Note 4) VGE = 15 V	Tj = 25°C	—	2.45	—	V
			Tj = 125°C	—	3.10	3.70	
			Tj = 150°C	—	3.25	—	
td(on)	Turn-on delay time	VCC = 1800 V IC = 1500 A VGE = ±15 V	Tj = 25°C	—	1.00	—	μs
			Tj = 125°C	—	0.95	1.25	
			Tj = 150°C	—	0.95	1.25	
tr	Turn-on rise time	VCC = 1800 V IC = 1500 A VGE = ±15 V	Tj = 25°C	—	0.28	—	μs
			Tj = 125°C	—	0.30	0.50	
			Tj = 150°C	—	0.30	0.50	
Eon(10%)	Turn-on switching energy (Note 5)	RG(on) = 1.6Ω Ls = 100 nH Inductive load	Tj = 25°C	—	2.45	—	J/P
			Tj = 125°C	—	2.90	—	
			Tj = 150°C	—	3.10	—	
Eon	Turn-on switching energy (Note 6)		Tj = 25°C	—	2.70	—	J/P
			Tj = 125°C	—	3.30	—	
			Tj = 150°C	—	3.60	—	
td(off)	Turn-off delay time	VCC = 1800 V IC = 1500 A VGE = ±15 V	Tj = 25°C	—	2.70	—	μs
			Tj = 125°C	—	2.80	3.30	
			Tj = 150°C	—	2.85	3.30	
tf	Turn-off fall time	VCC = 1800 V IC = 1500 A VGE = ±15 V	Tj = 25°C	—	0.30	—	μs
			Tj = 125°C	—	0.35	1.00	
			Tj = 150°C	—	0.40	1.00	
Eoff(10%)	Turn-off switching energy (Note 5)	RG(off) = 5.6Ω Ls = 100 nH Inductive load	Tj = 25°C	—	2.00	—	J/P
			Tj = 125°C	—	2.45	—	
			Tj = 150°C	—	2.50	—	
Eoff	Turn-off switching energy (Note 6)		Tj = 25°C	—	2.20	—	J/P
			Tj = 125°C	—	2.70	—	
			Tj = 150°C	—	2.80	—	
VEC	Emitter-collector voltage (Note 2)	IE = 1500 A (Note 4) VGE = 0 V	Tj = 25°C	—	2.15	—	V
			Tj = 125°C	—	2.30	2.80	
			Tj = 150°C	—	2.25	—	

HVIGBT (High Voltage Insulated Gate Bipolar Transistor) Modules

ELECTRICAL CHARACTERISTICS (continuation)

Symbol	Item	Conditions	Limits			Unit	
			Min	Typ	Max		
t _{rr}	Reverse recovery time (Note 2)	V _{CC} = 1800 V I _C = 1500 A V _{GE} = ±15 V R _{G(on)} = 1.6 Ω L _s = 100 nH Inductive load	T _J = 25°C	—	0.50	—	μs
			T _J = 125°C	—	0.70	—	
			T _J = 150°C	—	0.80	—	
I _{rr}	Reverse recovery current (Note 2)		T _J = 25°C	—	1250	—	A
			T _J = 125°C	—	1500	—	
			T _J = 150°C	—	1550	—	
Q _{rr}	Reverse recovery charge (Note 2)		T _J = 25°C	—	1050	—	μC
			T _J = 125°C	—	1700	—	
			T _J = 150°C	—	2000	—	
E _{rec(10%)}	Reverse recovery energy (Note 2)(Note 5)	T _J = 25°C	—	1.05	—	J/P	
		T _J = 125°C	—	1.75	—		
		T _J = 150°C	—	2.00	—		
E _{rec}	Reverse recovery energy (Note 2)(Note 6)	T _J = 25°C	—	1.20	—	J/P	
		T _J = 125°C	—	2.00	—		
		T _J = 150°C	—	2.30	—		

THERMAL CHARACTERISTICS

Symbol	Item	Conditions	Limits			Unit
			Min	Typ	Max	
R _{th(j-c)Q}	Thermal resistance	Junction to Case, IGBT part	—	—	8.0	K/kW
R _{th(j-c)R}		Junction to Case, FWDi part	—	—	15.0	
R _{th(c-f)}	Contact thermal resistance	Case to Fin, λ _{grease} = 1W/m-K, D(c-f) = 100 μm	—	6.0	—	K/kW

MECHANICAL CHARACTERISTICS

Symbol	Item	Conditions	Limits			Unit
			Min	Typ	Max	
M _t	Mounting torque	M8: Main terminals screw	7.0	—	22.0	N·m
M _s		M6: Mounting screw	3.0	—	6.0	
M _t		M4: Auxiliary terminals screw	1.0	—	3.0	
m	Mass		—	1.2	—	kg
CTI	Comparative tracking index		600	—	—	—
d _a	Clearance		19.5	—	—	mm
d _s	Creepage distance		32.0	—	—	mm
LP _{CE}	Parasitic stray inductance		—	11.0	—	nH
R _{CC+EE'}	Internal lead resistance	T _C = 25°C	—	0.12	—	mΩ
r _g	Internal gate resistor	T _C = 25°C	—	1.5	—	Ω

- Note 1. Pulse width and repetition rate should be such that junction temperature (T_J) does not exceed T_{opmax} rating (150°C).
 2. The symbols represent characteristics of the anti-parallel, emitter to collector free-wheel diode (FWDi).
 3. Junction temperature (T_J) should not exceed T_{Jmax} rating (150°C).
 4. Pulse width and repetition rate should be such as to cause negligible temperature rise.
 5. E_{on(10%)} / E_{off(10%)} / E_{rec(10%)} are the integral of 0.1V_{CE} x 0.1I_C x dt.
 6. The integration range of E_{on} / E_{off} / E_{rec} according to IEC 60747.

PRELIMINARY
 Notice: This is not a final specification.
 Some parametric limits are subject to change.

CM1500HC-66R

**HIGH POWER SWITCHING USE
 INSULATED TYPE**

4th-Version HVIGBT (High Voltage Insulated Gate Bipolar Transistor) Modules

PERFORMANCE CURVES

**OUTPUT CHARACTERISTICS
 (TYPICAL)**

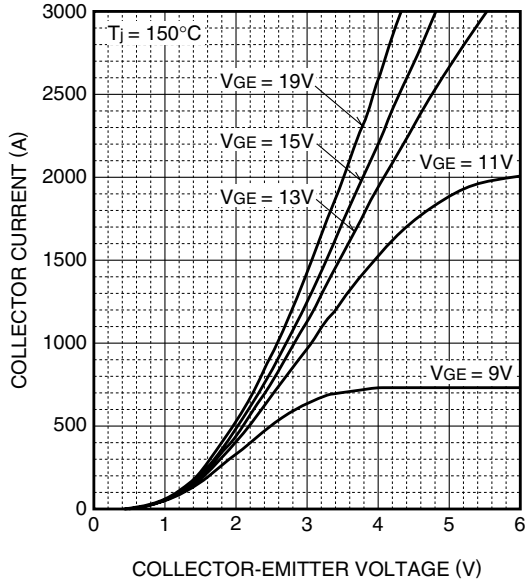

**TRANSFER CHARACTERISTICS
 (TYPICAL)**

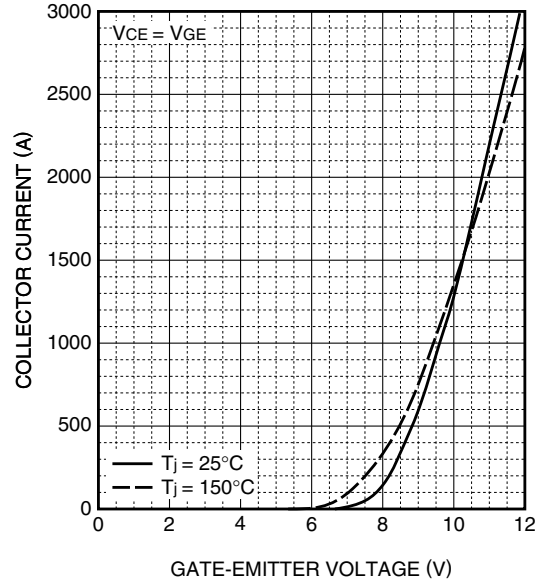

**COLLECTOR-EMITTER SATURATION VOLTAGE
 CHARACTERISTICS
 (TYPICAL)**

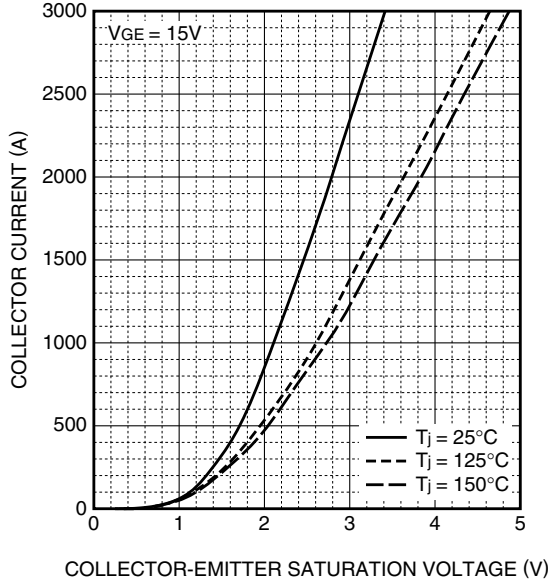

**FREE-WHEEL DIODE FORWARD
 CHARACTERISTICS
 (TYPICAL)**

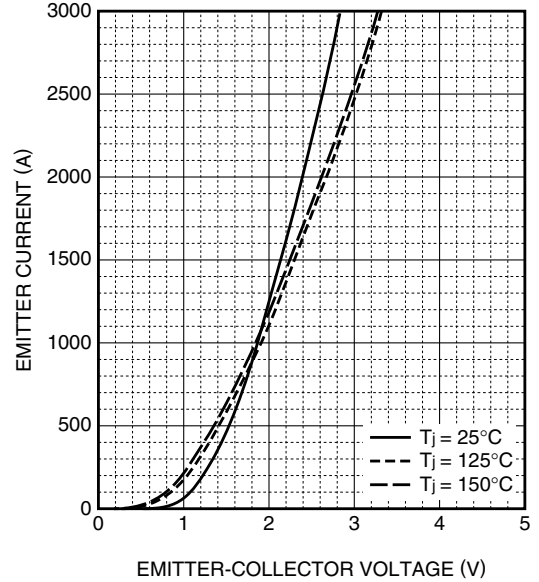

PRELIMINARY
 Notice: This is not a final specification.
 Some parametric limits are subject to change.

CM1500HC-66R

**HIGH POWER SWITCHING USE
 INSULATED TYPE**

4th-Version HVIGBT (High Voltage Insulated Gate Bipolar Transistor) Modules

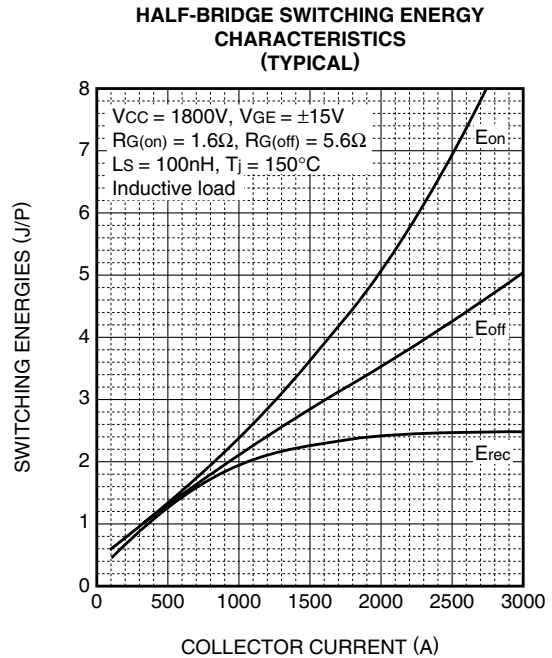
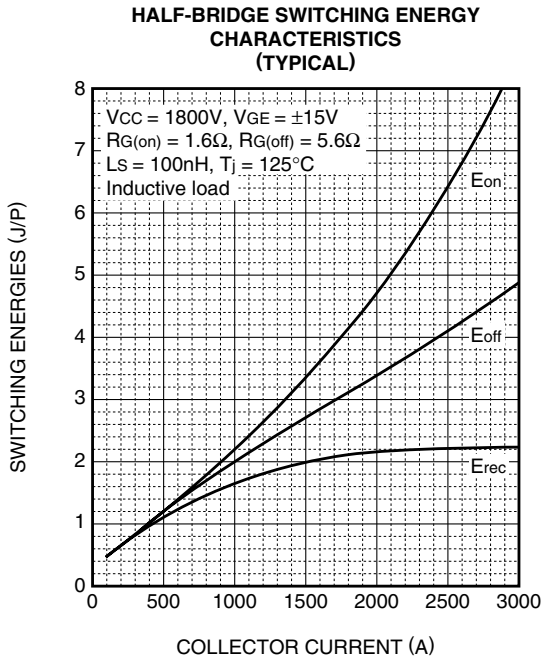
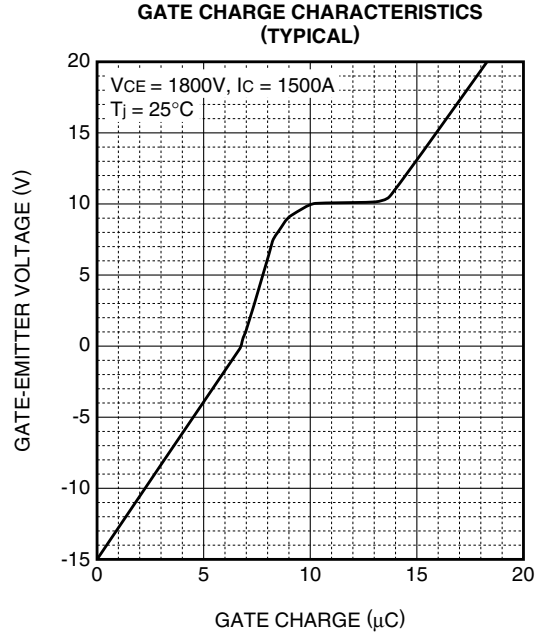
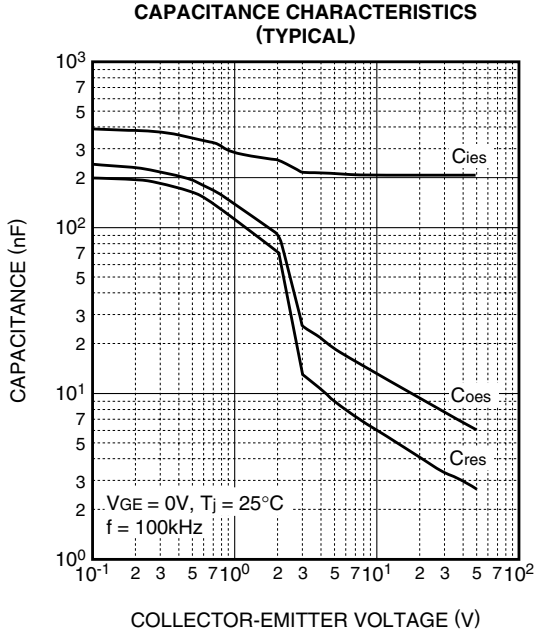

PRELIMINARY
 Notice: This is not a final specification.
 Some parametric limits are subject to change.

CM1500HC-66R

HIGH POWER SWITCHING USE
 INSULATED TYPE

4th-Version HVIGBT (High Voltage Insulated Gate Bipolar Transistor) Modules

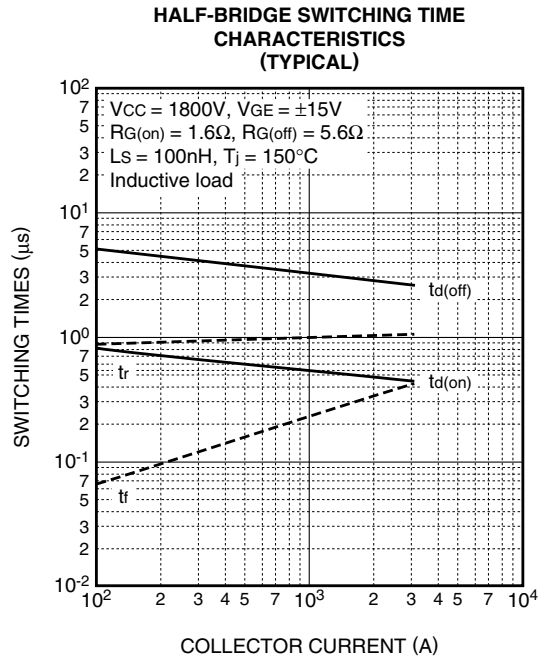
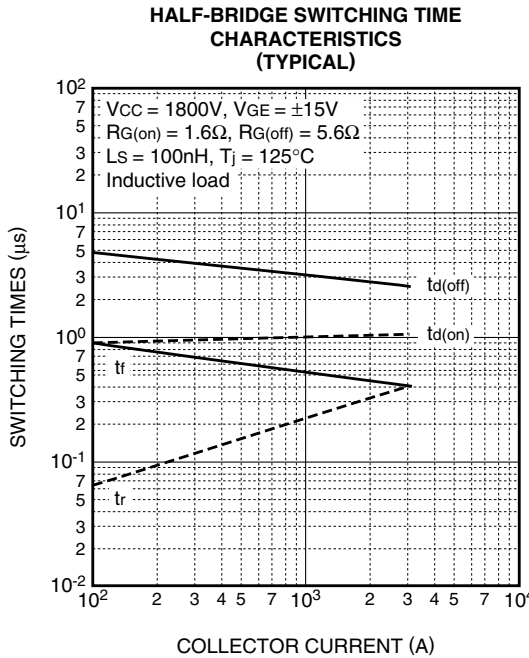
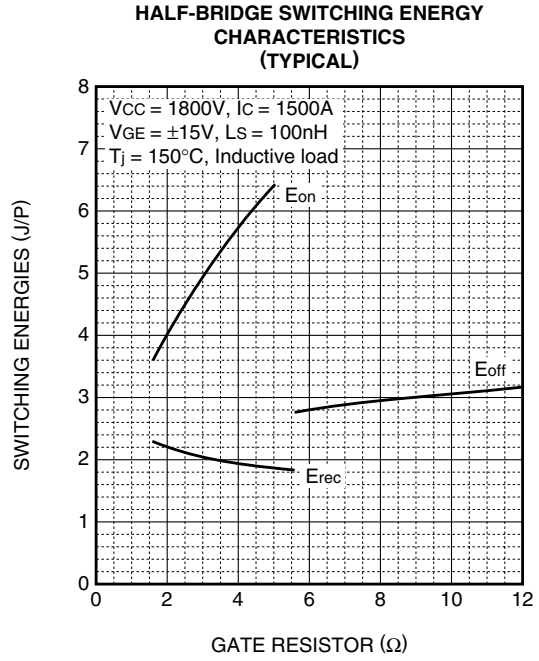
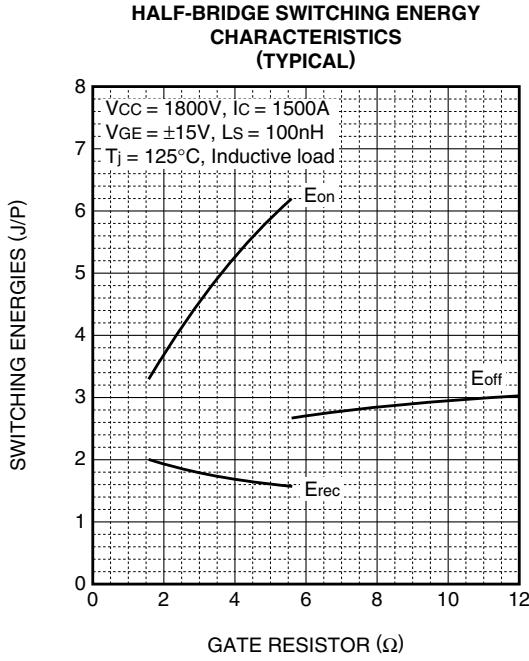

PRELIMINARY
 Notice: This is not a final specification.
 Some parametric limits are subject to change.

CM1500HC-66R

**HIGH POWER SWITCHING USE
 INSULATED TYPE**

4th-Version HVIGBT (High Voltage Insulated Gate Bipolar Transistor) Modules

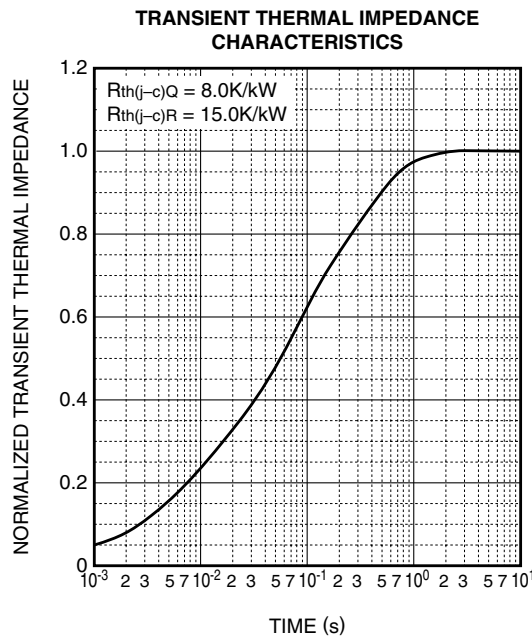
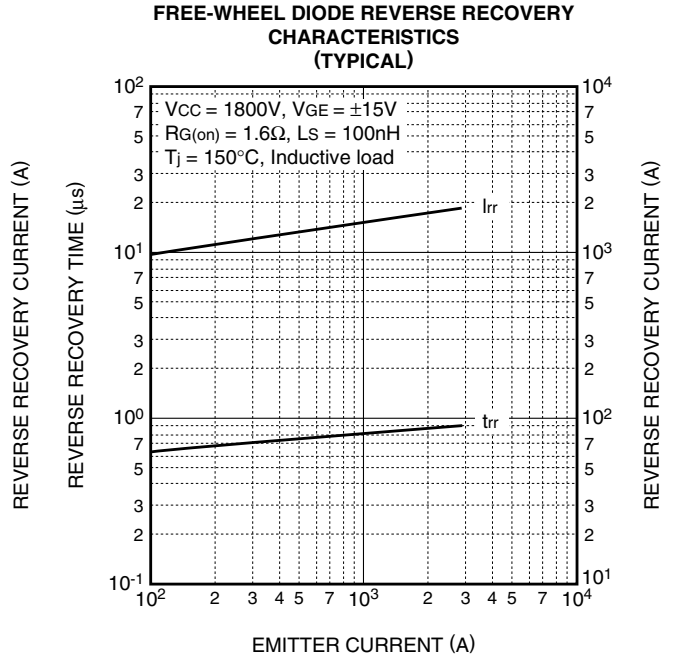
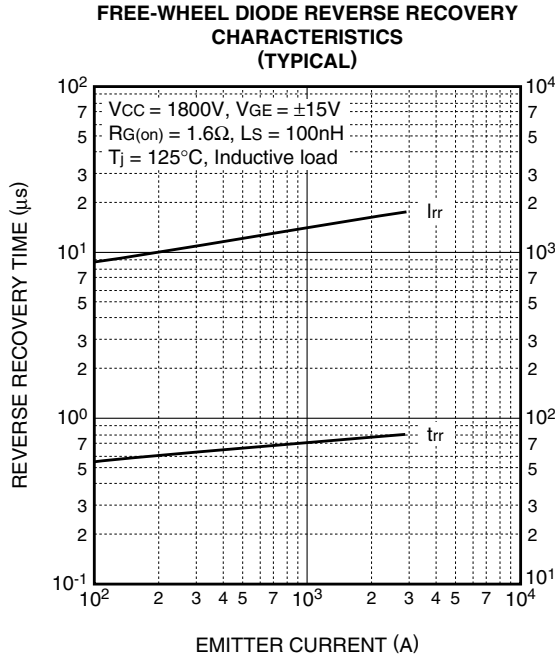

$$Z_{th(j-c)}(t) = \sum_{i=1}^n R_i \left\{ 1 - \exp\left(-\frac{t}{\tau_i}\right) \right\}$$

	1	2	3	4
R_i [K/kW] :	0.0096	0.1893	0.4044	0.3967
τ_i [sec] :	0.0001	0.0058	0.0602	0.3512

PRELIMINARY
 Notice: This is not a final specification.
 Some parametric limits are subject to change.

CM1500HC-66R

**HIGH POWER SWITCHING USE
 INSULATED TYPE**

4th-Version HVIGBT (High Voltage Insulated Gate Bipolar Transistor) Modules

REVERSE BIAS SAFE OPERATING AREA (RBSOA)

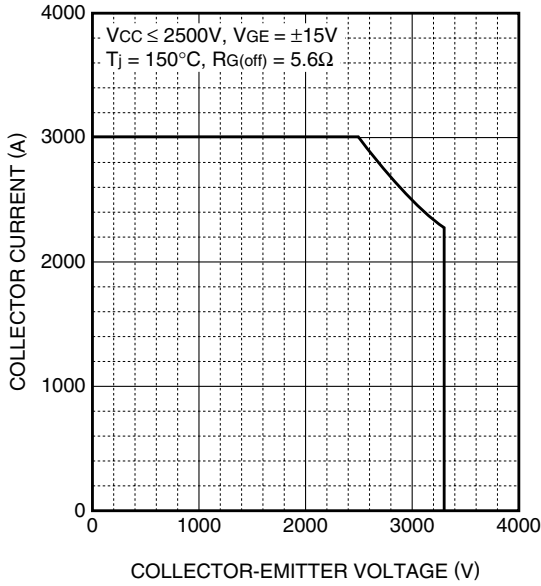

SHORT CIRCUIT SAFE OPERATING AREA (SCSOA)

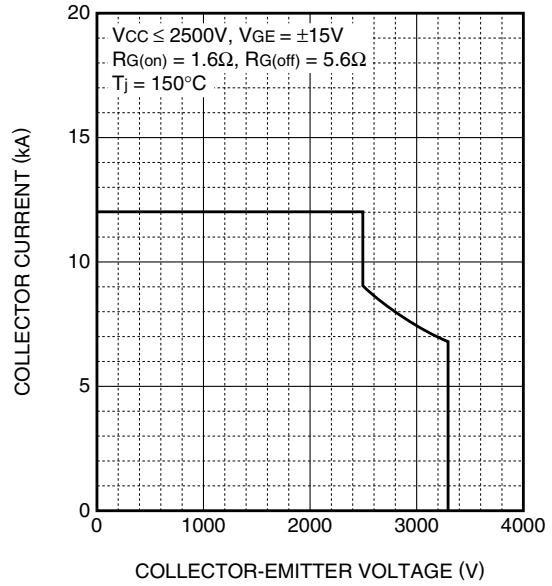

FREE-WHEEL DIODE REVERSE RECOVERY SAFE OPERATING AREA (RRSOA)

