

MGFC39V5867

5.8~6.75GHz BAND 8W INTERNALLY MATCHED GaAs FET

DESCRIPTION

The MGFC39V5867 device is an internally impedance-matched GaAs power FET especially designed for use in 5.8 ~ 6.75GHz band amplifiers. The hermetically sealed metal-ceramic package guarantees high reliability.

FEATURES

- Class A operation
- Internally matched to 50(ohm) system
- High output power
P1dB = 39dBm (TYP.) @ f=5.8 ~ 6.75 GHz
- High power gain
GLP = 9 dB (TYP.) @ f=5.8 ~ 6.75 GHz

APPLICATION

VSAT

RECOMMENDED BIAS CONDITIONS

VDS = 10 (V)
ID=2.4(A)
RG=50 (ohm)

OUTLINE DRAWING Unit : millimeters

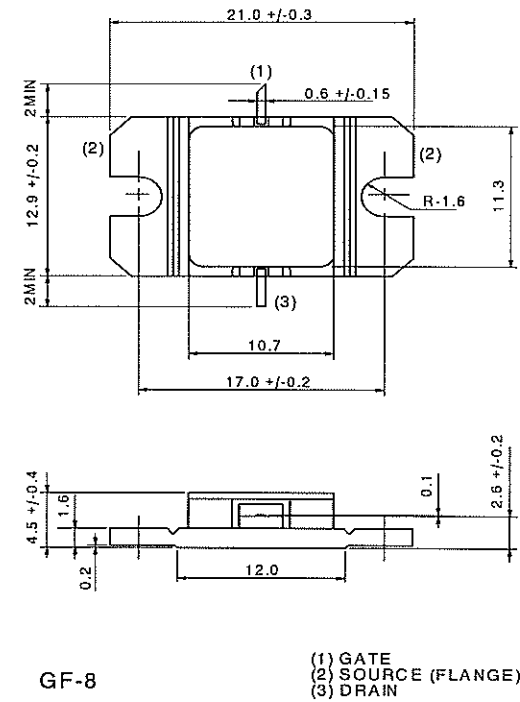

GF-8

(1) GATE
(2) SOURCE (FLANGE)
(3) DRAIN

ABSOLUTE MAXIMUM RATINGS (Ta=25deg.C)

Symbol	Parameter	Ratings	Unit
VGDO	Gate to drain voltage	-15	V
VGSO	Gate to source voltage	-15	V
ID	Drain current	7.5	A
IGR	Reverse gate current	-20	mA
IGF	Forward gate current	42	mA
PT *1	Total power dissipation	42.8	W
Tch	Channel temperature	175	deg.C
Tstg	Storage temperature	-65 / +175	deg.C

*1 : Tc=25deg.C

< Keep safety first in your circuit designs! >
Mitsubishi Electric Corporation puts the maximum effort into making semiconductor products better and more reliable, but there is always the possibility that trouble may occur with them. Trouble with semiconductors may lead to personal injury, fire or property damage. Remember to give due consideration to safety when making your circuit designs, with appropriate measures such as (1) placement of substitutive, auxiliary circuits, (2) use of non-flammable material or (3) prevention against any malfunction or mishap.

ELECTRICAL CHARACTERISTICS (Ta=25deg.C)

Symbol	Parameter	Test conditions	Limits			Unit
			Min.	Typ.	Max.	
IDSS	Saturated drain current	VDS=3V, VGS=0V	-	-	7.5	
gm	Transconductance	VDS=3V, ID=2.2A	-	2	-	
VGS(off)	Pinch-off voltage	VDS=3V, ID=20mA	-	-	-4.5	V
P1dB	Output power at 1dB gain	VDS=10V, ID(RF off)=2.4A. f=5.8 ~ 6.75GHz	38.0	39.0	-	dBm
GLP	Linear power gain		8.0	9.0	-	dB
ID	Drain Current		-	-	3	A
P.A.E.	Power added efficiency		-	30	-	%
Rth(ch-c)	Thermal resistance	*1 delta Vf method	-	-	3.5	deg.C/W

*1 : Channel-case



MITSUBISHI
ELECTRIC

MGFC39V5867

5.8 - 6.75GHz BAND 8W INTERNALLY MATCHED GaAs FET

TYPICAL CHARACTERISTICS (Ta=25deg.C)

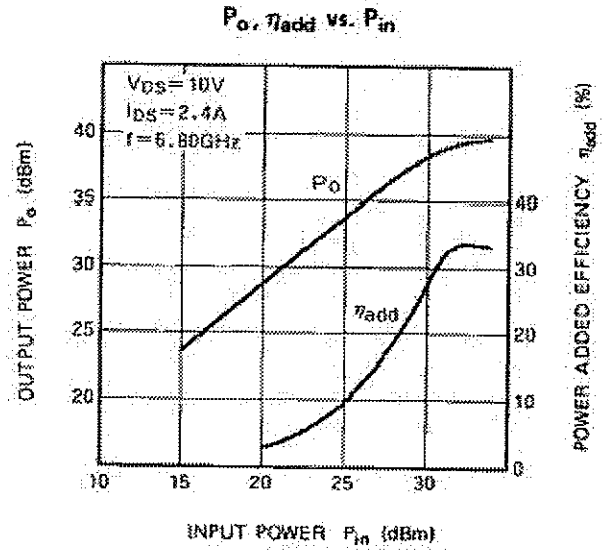
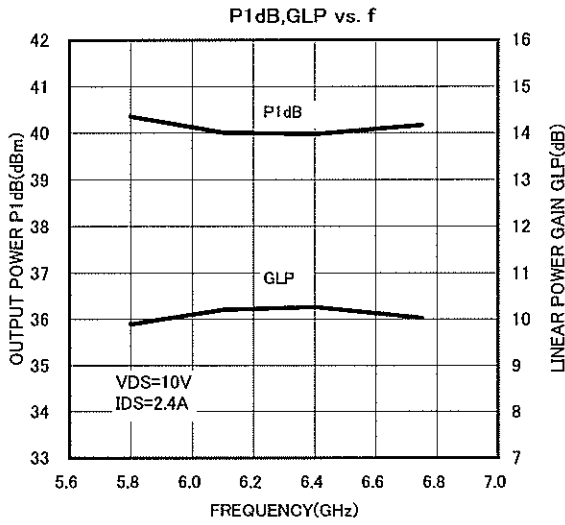

S parameters (Ta=25deg.C , VDS=10(V),IDS=2.4(A))

f (GHz)	S-Parameters (TYP.)							
	S11		S21		S12		S22	
	Magn.	Angle(deg)	Magn.	Angle(deg)	Magn.	Angle(deg)	Magn.	Angle(deg)
5.8	0.669	-173	2.927	13	0.043	-28	0.188	-100
5.9	0.658	171	2.916	-1	0.050	-46	0.155	-130
6.0	0.645	156	2.937	-14	0.055	-63	0.148	-160
6.1	0.632	143	2.948	-28	0.055	-76	0.166	176
6.2	0.618	130	2.933	-42	0.058	-90	0.201	154
6.3	0.598	119	2.928	-55	0.060	-104	0.241	139
6.4	0.574	108	2.909	-68	0.063	-117	0.282	126
6.5	0.543	98	2.903	-81	0.066	-131	0.320	115
6.6	0.502	87	2.927	-94	0.070	-143	0.353	104
6.7	0.450	76	2.945	-107	0.071	-156	0.380	94
6.8	0.386	65	2.995	-121	0.076	-168	0.398	84



MITSUBISHI SEMICONDUCTOR <GaAs FET>

MGFC39V5867

5.8 ~ 6.75GHz BAND 8W INTERNALLY MATCHED GaAs FET