

APPLICATION NOTE

Document NO. AN-GEN-034-B

Date : 5th Dec. 2003

Prepared : N.Watanabe
M.Wada

Confirmed : S.Kametani

SUBJECT: Recommended mounted & precaution for RD07MVS1&RD02MUS1

SUMMARY:

This application note shows recommendation device mount method & precaution for RD07MVS1&RD02MUS1.

1. Recommended P.C.B layout
2. Recommended mount method
3. Pch vs Ta at recommend device mounting
4. Junction thermal calculation
5. Recommended reflow soldering
6. Precaution

2. Recommended mount method

In order to heat radiation, Mitsubishi recommends device mount like Fig.1 . And this PCB has regular triangle arrangement 13 through holes (Page2/7) at the underside of source area. And the plating thickness of through hole is 0.05mm. Also,fix the PCB with screws

Fig.1

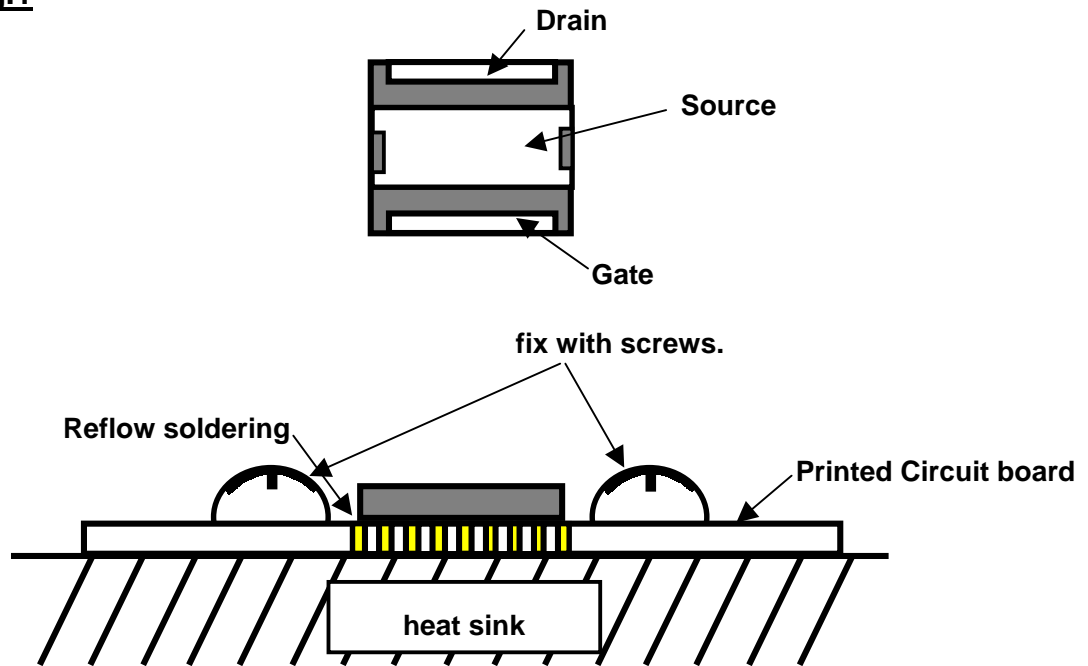

Note : Mitsubishi Heat Sink size=40.0*90.0*10.0 UNIT:mm

If you need to operate more high power ,Mitsubishi recommends device mount like Fig.2. (Please fix the source of device backside directly on heatsink by solder.)

Fig.2

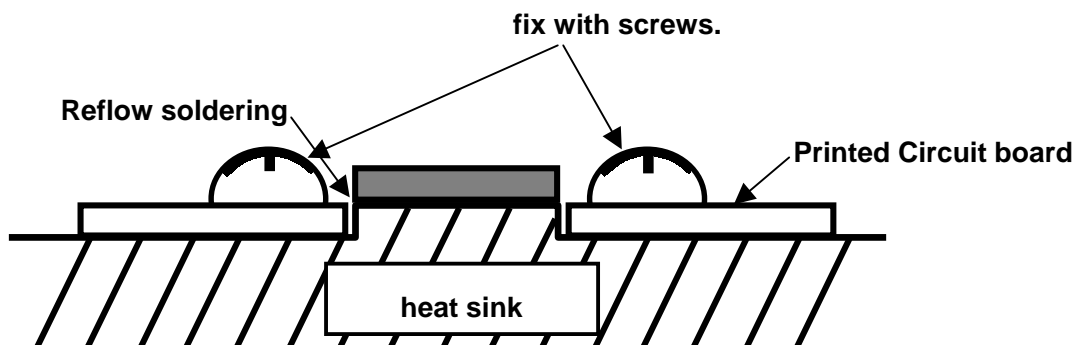

3. Pch vs Ta at recommend device mounting

Fig.3

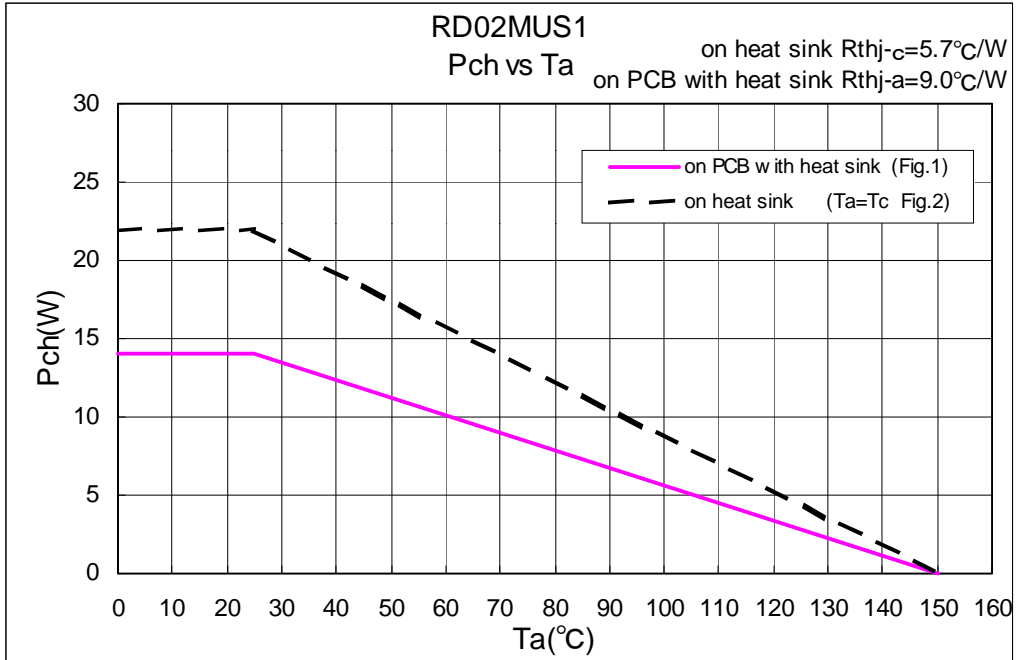
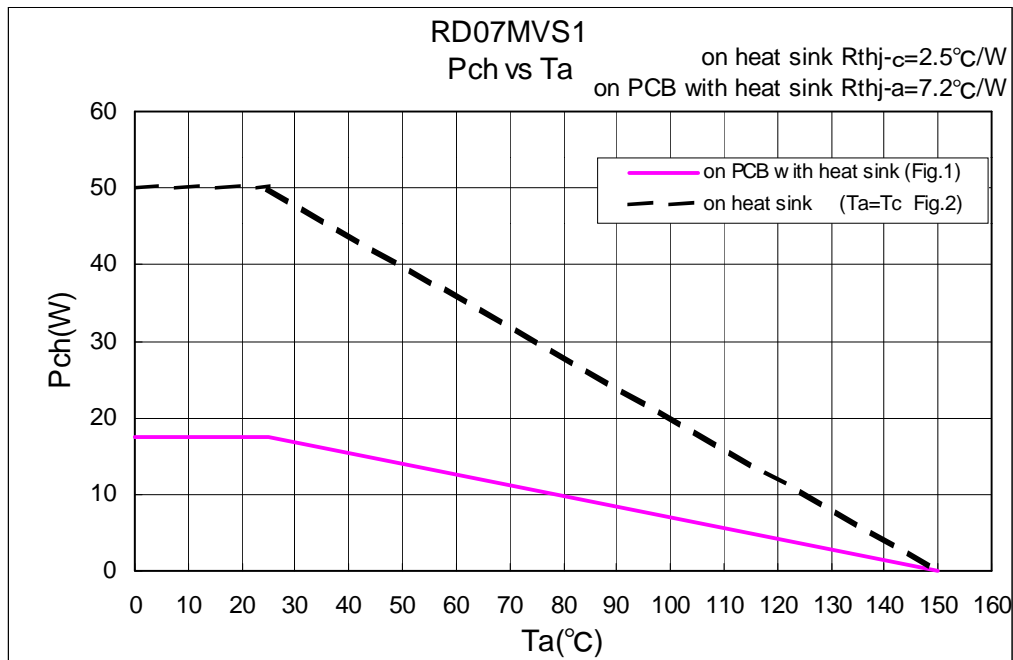

Fig.4



Note : Mitsubishi PCB size=40.0*90.0 , t=0.8 ,material:FR4

The plating thickness of through hole=0.05

Mitsubishi heat sink size=40.0*90.0*10.0 UNIT:mm

4. Junction thermal calculation

This example shows junction thermal calculation of RD02MUS1 and RD07MVS1.

RD02MUS1

1. Thermal resistance (Rthj-a) typical value @ on PCB with regular triangle arrangement through hole mounting heat sink.

$$R_{thj-a}=9.0 \text{ } ^\circ\text{C} / \text{W}$$

2. Temperature of chip junction part (Tj)

In case of Ta=60 °C

$$T_j=78.7 \text{ } ^\circ\text{C} @ \text{Vdd}=7.2\text{V}, \text{Pin}=0.05\text{W}, \text{Po}=2.0\text{W}, \text{Idd}=0.56\text{A}$$

$$\#T_j(^{\circ}\text{C}) = R_{thj-a} (9.0) * P_d(2.082) + T_a(60)$$

$$P_d(\text{W}) = V_{dd}(7.2) * I_{dd}(0.56) - P_o(2.0) + P_{in}(0.05)$$

This value (Tj=78.7°C) is lower than 150°C of the case Absolute Maximum Ratings, And gets to operate in the sufficiently derated condition.

RD07MVS1

1. Thermal resistance (Rthj-a) typical value @ on PCB with regular triangle arrangement through hole mounting heat sink.

$$R_{thj-a}=7.2 \text{ } ^\circ\text{C} / \text{W}$$

2. Temperature of chip junction part (Tj)

In case of Ta=60 °C

$$T_j=115.7 \text{ } ^\circ\text{C} @ \text{Vdd}=7.2\text{V}, \text{Pin}=0.7\text{W}, \text{Po}=7.0\text{W}, \text{Idd}=1.95\text{A}$$

$$\# T_j(^{\circ}\text{C}) = R_{thj-a} (7.2) * P_d(7.74) + T_a(60)$$

$$P_d(\text{W}) = V_{dd}(7.2) * I_{dd}(1.95) - P_o(7.0) + P_{in}(0.7)$$

This value (Tj=115.7°C) is lower than 150°C of the case Absolute Maximum Ratings, And gets to operate in the sufficiently derated condition.

5. Recommended reflow soldering

Regarding to reflow soldering, Mitsubishi recommend the heat profile of Fig.5.

Fig.5

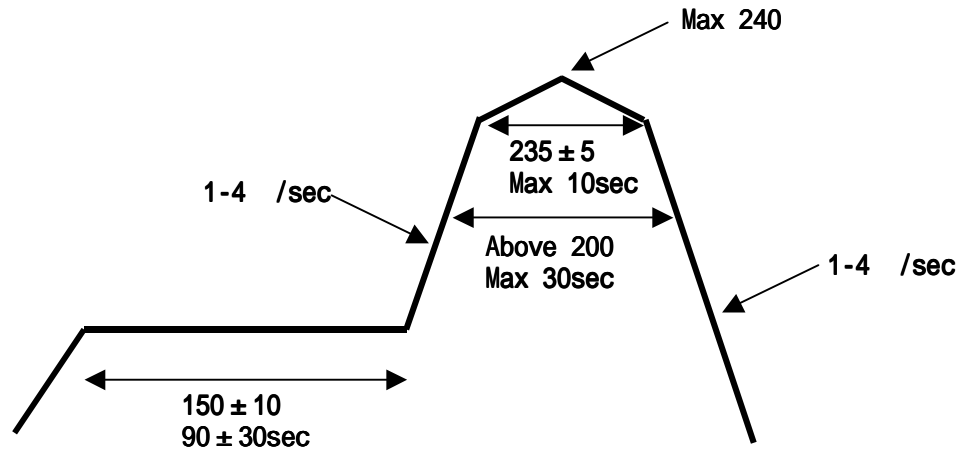

6. Precaution

GENERAL

RD**** is designed for Mobile Communication terminals. They are not designed for Base Station applications. MITSUBISHI ELECTRIC cannot take any liability for failures resulting from Base Stations operation time or conditions exceeding those normally found in Mobile Communication terminals. In the case of using this devices for Base Stations or similar applications which have same operating conditions described above, the following conditions may result in failures.

1) Junction Temperature.

Keep the operating junction temperature of MOSFETs $T_{ch}(op)$ less than 120deg.C.

2) Frequent on/off switching.

On/off switching causes thermal expansion of the resin covering chips and wire bonds. In Frequent and long term Base Station usage this mechanical stress causes the wire bonds to break resulting in reduced or no output power. Other problems can occur when applying RD**** for highly demanding Base Station applications.

Handling precautions

- 1). MOS FET devices have lower surge endurance compared with silicon bipolar devices. And there is a possibility of burn-out when static electricity or surge is added to devices.
- 2). These devices do not have a surge protection circuit (internal zener diode) from gate to source.

Limiting mechanical stress

1) Board Assembly : Keep mechanical stress to the devices as low as possible.

Electrical performance degradation may occur when the device is under high mechanical stress such as board bending during reflow soldering process ,board separation process , mounting to chassis, etc.

Cause of the performance degradation is delamination between molding compound and leadframe within the device due to the transmitted mechanical stress during board bending. Please adhere to the following guidelines in your assembly process.

2) Guideline for limiting mechanical stress to the device(Only the direction of Gate-Drain)

The curvature radius of the board shall be larger than 507mm. For example, the board warpage shall be smaller than 2mm in case of the 90mm length board.(Fig.6) In addition to limiting the curvature radius (2mm at 90mm length), the number of repetition for such stress should be limited to 5 times maximum. This kind of warpage is caused both mechanically and thermally. The level of mechanical stress depends on board materials and design layout, (location and direction of the devices) ,please monitor and control curvature radius or warpage of board after re-flow process.

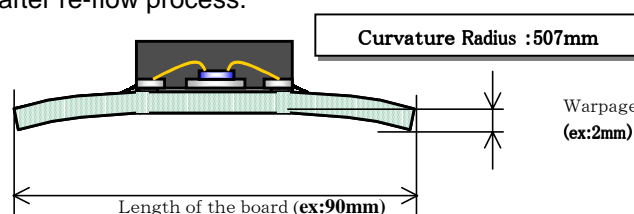

Fig.6