

# APPLICATION NOTE

Document No. AN-VHF-034

Date: 10<sup>th</sup> Feb. 2006

Prepared: E.Akiyama  
S.Kametani

Confirmed: T.Ohkawa

**SUBJECT:** RD12MVP1 135-175MHz RF characteristics data

## SUMMARY:

This application note shows the RF characteristics (Frequency Characteristics, Pin vs. Pout characteristics and Vdd vs. Pout characteristics) data of RD12MVP1 using Broad-Band Test Fixture.

### - Sample history:

RD12MVP1: Lot number "059XA-G"

### - Evaluate conditions:

Frequency Characteristics @f=135 to 175MHz: Pin=1.0/0.7/0.5/0.3W, Vdd=7.2V, Idq=1.0A (Vgg adj.)

Pin vs. Pout Characteristics @ f=135/155/175MHz: Vdd=7.2V, Idq=0.7/1.0A (Vgg adj.)

Vdd vs. Pout Characteristics @ f=135/155/175MHz: Pin=1.0W, Vdd=6 to 10V, Idq=1.0A (Vgg adj.)

### - Results:

Page 2 to 5 shows the 135 to 175MHz Frequency Characteristics data.

Page 6 to 11 shows the Pin vs. Pout Characteristics data.

Page 12 to 14 shows the Vdd vs. Pout Characteristics data.

Page 15 to 16 shows the Broad-band Equivalent Circuit.

**RD12MVP1 Frequency Characteristics (@ f=135 ~ 175MHz Broad-band Fixture; Pin=1.0W)**

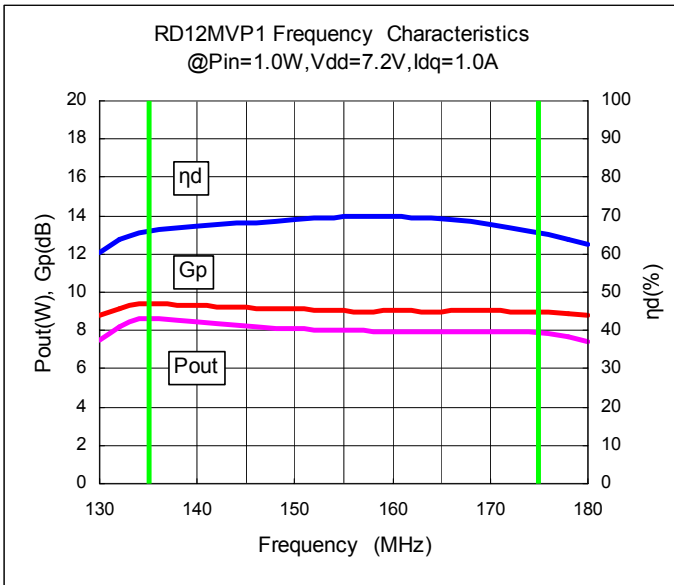

Lot No. 059XA-G

Vdd= 7.2 V  
 Vgg= 4.26 V  
 Idq= 1.0 A  
 Pin= 1.0 W

Measurement date : 2006/2/10

Freq. (MHz)	Pout		Gp	ID(RF)	ηd	Return Loss.	Harmonics	Harmonics
	(dBm)	(W)	(dB)	(A)	(%)	(dB)	2fo(dBc)	3fo(dBc)
130	38.8	7.54	8.8	1.74	60.26	-1.62	-24.82	-45.80
132	39.1	8.21	9.1	1.79	63.68	-1.71	-25.90	-47.26
134	39.4	8.61	9.4	1.82	65.70	-1.83	-26.79	-48.26
136	39.3	8.60	9.4	1.80	66.29	-1.98	-27.71	-49.41
138	39.3	8.52	9.3	1.77	66.69	-2.14	-28.54	-50.13
140	39.3	8.43	9.3	1.75	67.11	-2.37	-29.39	-51.41
142	39.2	8.34	9.2	1.72	67.57	-2.62	-30.27	-51.95
144	39.2	8.28	9.2	1.69	68.08	-2.92	-31.09	-52.34
146	39.1	8.18	9.1	1.67	68.21	-3.30	-31.90	-52.31
148	39.1	8.13	9.1	1.65	68.63	-3.76	-32.58	-51.94
150	39.1	8.08	9.1	1.63	68.98	-4.33	-33.19	-52.17
152	39.1	8.04	9.1	1.61	69.30	-5.05	-33.89	-52.53
154	39.0	7.99	9.1	1.60	69.43	-5.93	-34.54	-52.96
156	39.0	7.97	9.0	1.59	69.62	-7.06	-35.12	-54.76
158	39.0	7.96	9.0	1.59	69.73	-8.53	-35.88	-55.95
160	39.0	7.95	9.0	1.59	69.65	-10.45	-36.58	-54.64
162	39.0	7.94	9.0	1.59	69.52	-13.10	-37.19	-54.55
164	39.0	7.95	9.0	1.59	69.32	-16.96	-37.78	-53.53
166	39.0	7.95	9.0	1.60	68.97	-22.25	-38.26	-54.61
168	39.0	7.95	9.0	1.62	68.40	-21.40	-39.07	-53.78
170	39.0	7.95	9.0	1.63	67.77	-16.31	-39.63	-54.27
172	39.0	7.93	9.0	1.65	66.95	-12.80	-40.56	-53.51
174	39.0	7.90	9.0	1.66	66.07	-10.35	-41.15	-52.45
176	38.9	7.81	9.0	1.67	64.96	-8.53	-41.19	-51.97
178	38.8	7.67	8.9	1.67	63.77	-7.15	-41.36	-52.60
180	38.7	7.44	8.8	1.66	62.36	-6.05	-41.73	-54.56

note: part of hatching show out of target

**RD12MVP1 Frequency Characteristics (@ f=135 ~ 175MHz Broad-band Fixture; Pin=0.7W)**

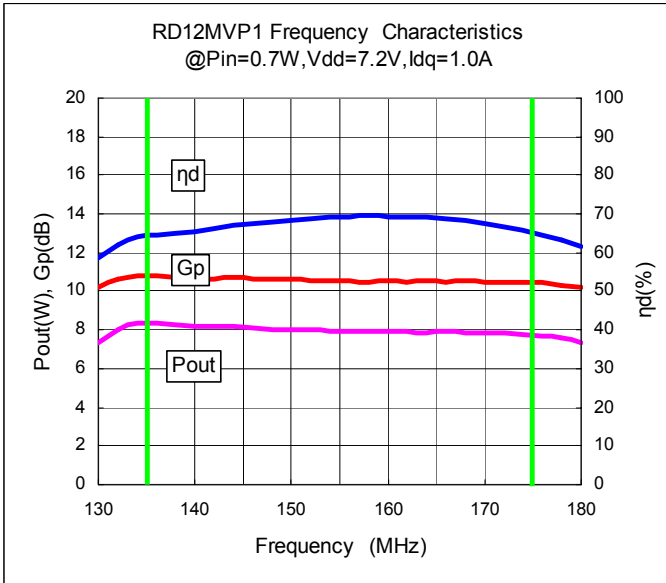

Lot No. 059XA-G  
 Vdd= 7.2 V  
 Vgg= 4.26 V  
 Idq= 1.0 A  
 Pin= 0.7 W

Measurement date: 2006/2/10

Freq. (MHz)	Pout		Gp (dB)	ID(RF) (A)	ηd (%)	Return Loss. (dB)	Harmonics 2fo(dBc)	Harmonics 3fo(dBc)
	(dBm)	(W)						
130	38.6	7.32	10.2	1.74	58.44	-1.52	-24.88	-45.97
132	39.0	7.99	10.6	1.79	61.94	-1.59	-26.01	-47.50
134	39.2	8.39	10.8	1.82	64.03	-1.73	-26.93	-48.15
136	39.2	8.37	10.8	1.80	64.49	-1.88	-27.81	-49.87
138	39.2	8.29	10.7	1.77	64.90	-2.06	-28.75	-50.89
140	39.2	8.23	10.7	1.74	65.51	-2.26	-29.54	-51.90
142	39.1	8.20	10.7	1.72	66.40	-2.52	-30.36	-52.69
144	39.1	8.14	10.7	1.69	66.93	-2.82	-31.12	-51.91
146	39.1	8.08	10.7	1.66	67.43	-3.20	-31.95	-52.33
148	39.1	8.04	10.6	1.64	67.96	-3.65	-32.66	-51.76
150	39.0	8.01	10.6	1.63	68.45	-4.21	-33.34	-52.02
152	39.0	7.99	10.5	1.61	68.84	-4.91	-33.99	-52.46
154	39.0	7.94	10.5	1.60	69.03	-5.78	-34.72	-52.87
156	39.0	7.91	10.6	1.59	69.22	-6.90	-35.31	-54.58
158	39.0	7.91	10.5	1.58	69.41	-8.34	-35.83	-55.51
160	39.0	7.89	10.6	1.58	69.35	-10.21	-36.73	-54.64
162	39.0	7.90	10.5	1.58	69.28	-12.79	-37.32	-55.02
164	39.0	7.89	10.5	1.59	69.00	-16.39	-37.98	-54.92
166	39.0	7.90	10.5	1.60	68.71	-21.06	-38.68	-54.63
168	39.0	7.89	10.5	1.61	68.15	-20.53	-39.54	-55.17
170	39.0	7.87	10.5	1.62	67.49	-15.98	-39.86	-53.93
172	38.9	7.84	10.5	1.64	66.60	-12.59	-40.43	-52.46
174	38.9	7.80	10.4	1.65	65.68	-10.19	-41.27	-52.32
176	38.9	7.70	10.5	1.66	64.45	-8.36	-41.26	-52.42
178	38.8	7.56	10.3	1.66	63.22	-6.98	-41.56	-52.63
180	38.7	7.33	10.2	1.65	61.74	-5.87	-41.78	-54.43

note: part of hatching show out of target

**RD12MVP1 Frequency Characteristics (@ f=135 ~ 175MHz Broad-band Fixture; Pin=0.5W)**

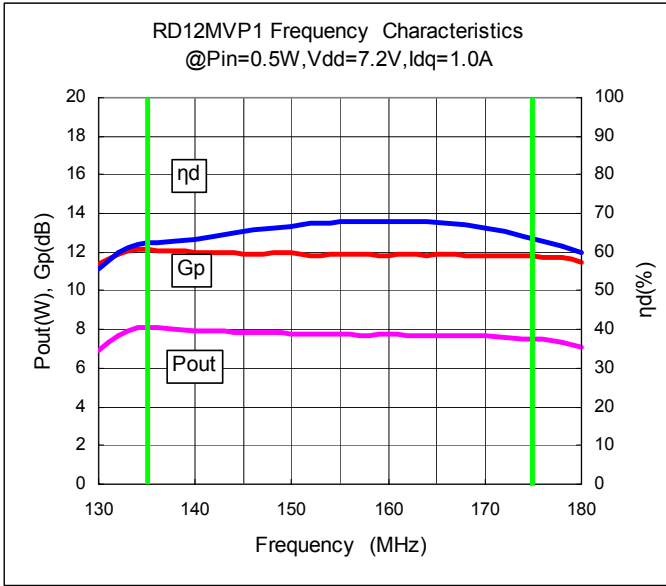

Lot No. 059XA-G

Vdd= 7.2 V  
 Vgg= 4.26 V  
 Idq= 1.0 A  
 Pin= 0.5 W

Measurement date: 2006/2/10

Freq. (MHz)	Pout (dBm)	Pout (W)	Gp (dB)	ID(RF) (A)	ηd (%)	Return Loss. (dB)	Harmonics 2fo(dBc)	Harmonics 3fo(dBc)
130	38.4	6.90	11.4	1.72	55.76	-1.42	-24.89	-45.84
132	38.9	7.70	11.9	1.79	59.90	-1.48	-26.07	-47.49
134	39.1	8.09	12.1	1.82	61.90	-1.62	-27.05	-48.55
136	39.1	8.08	12.1	1.80	62.26	-1.79	-27.98	-49.41
138	39.0	8.01	12.0	1.77	62.73	-1.97	-28.91	-50.89
140	39.0	7.95	12.0	1.74	63.38	-2.18	-29.69	-51.35
142	39.0	7.92	12.0	1.72	64.10	-2.43	-30.45	-52.59
144	39.0	7.86	12.0	1.69	64.82	-2.74	-31.28	-52.56
146	39.0	7.86	11.9	1.66	65.73	-3.12	-31.96	-52.38
148	38.9	7.82	12.0	1.64	66.21	-3.54	-32.68	-52.13
150	38.9	7.80	12.0	1.62	66.79	-4.09	-33.30	-52.34
152	38.9	7.79	11.9	1.61	67.33	-4.79	-33.92	-53.36
154	38.9	7.76	11.9	1.59	67.66	-5.65	-34.51	-53.37
156	38.9	7.72	11.9	1.58	67.82	-6.76	-35.32	-54.84
158	38.9	7.72	11.9	1.58	68.00	-8.17	-35.77	-56.12
160	38.9	7.72	11.8	1.58	68.11	-10.05	-36.61	-55.75
162	38.9	7.71	11.9	1.58	68.00	-12.55	-37.16	-55.03
164	38.9	7.71	11.8	1.58	67.82	-15.99	-37.96	-54.49
166	38.9	7.70	11.9	1.59	67.39	-19.96	-38.76	-54.02
168	38.9	7.69	11.8	1.60	66.88	-19.44	-39.50	-53.08
170	38.8	7.67	11.8	1.61	66.14	-15.41	-40.11	-53.93
172	38.8	7.63	11.8	1.62	65.26	-12.20	-40.79	-53.28
174	38.8	7.55	11.9	1.64	64.10	-9.86	-41.36	-52.77
176	38.7	7.48	11.7	1.65	63.03	-8.10	-41.60	-51.36
178	38.6	7.31	11.7	1.65	61.51	-6.71	-41.67	-53.58
180	38.5	7.10	11.5	1.64	60.05	-5.64	-42.13	-54.04

note: part of hatching show out of target

**RD12MVP1 Frequency Characteristics (@ f=135 ~ 175MHz Broad-band Fixture; Pin=0.3W)**

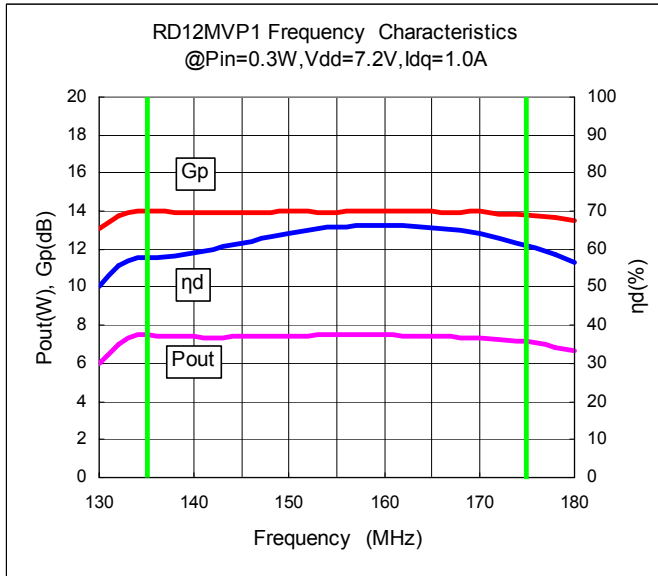

Lot No. 059XA-G  
 Vdd= 7.2 V  
 Vgg= 4.26 V  
 Idq= 1.0 A  
 Pin= 0.3 W

Measurement date: 2006/2/10

Freq. (MHz)	Pout		Gp (dB)	ID(RF) (A)	ηd (%)	Return Loss. (dB)	Harmonics 2fo(dBc)	Harmonics 3fo(dBc)
	(dBm)	(W)						
130	37.8	6.01	13.1	1.66	50.32	-1.22	-24.80	-46.07
132	38.5	7.02	13.7	1.76	55.59	-1.27	-26.13	-47.25
134	38.7	7.49	14.0	1.80	57.76	-1.44	-27.27	-48.33
136	38.7	7.47	14.0	1.79	57.88	-1.63	-28.28	-49.63
138	38.7	7.40	14.0	1.77	58.17	-1.82	-29.10	-51.08
140	38.7	7.39	13.9	1.74	59.06	-2.03	-29.95	-52.20
142	38.7	7.35	14.0	1.71	59.87	-2.27	-30.72	-52.04
144	38.7	7.39	13.9	1.68	61.09	-2.58	-31.52	-52.14
146	38.7	7.42	13.9	1.66	62.21	-2.93	-32.13	-52.16
148	38.7	7.45	14.0	1.64	63.21	-3.38	-32.84	-52.16
150	38.7	7.46	14.0	1.62	64.05	-3.92	-33.48	-52.50
152	38.7	7.46	14.0	1.60	64.80	-4.60	-34.13	-52.50
154	38.8	7.51	14.0	1.59	65.71	-5.46	-34.82	-53.38
156	38.7	7.48	14.0	1.58	65.87	-6.57	-35.47	-55.32
158	38.7	7.49	14.0	1.57	66.27	-7.99	-35.98	-56.15
160	38.7	7.47	14.0	1.57	66.28	-9.83	-36.63	-54.97
162	38.7	7.45	14.0	1.56	66.15	-12.27	-37.36	-55.12
164	38.7	7.43	14.0	1.57	65.87	-15.45	-37.86	-53.90
166	38.7	7.41	13.9	1.57	65.46	-18.43	-38.94	-54.43
168	38.7	7.37	13.9	1.58	64.77	-17.40	-39.58	-54.82
170	38.7	7.34	14.0	1.59	64.12	-14.05	-40.39	-54.35
172	38.6	7.25	13.9	1.60	62.89	-11.26	-41.09	-53.47
174	38.6	7.18	13.8	1.61	61.81	-9.14	-41.36	-52.80
176	38.5	7.05	13.8	1.62	60.30	-7.48	-41.63	-52.98
178	38.4	6.87	13.7	1.63	58.63	-6.18	-41.87	-53.51
180	38.2	6.64	13.5	1.62	56.75	-5.13	-42.09	-54.20

note: part of hatching show out of target

RD12MVP1 Pin vs. Pout Characteristics (@ f=135MHz;Idq=1.0A)

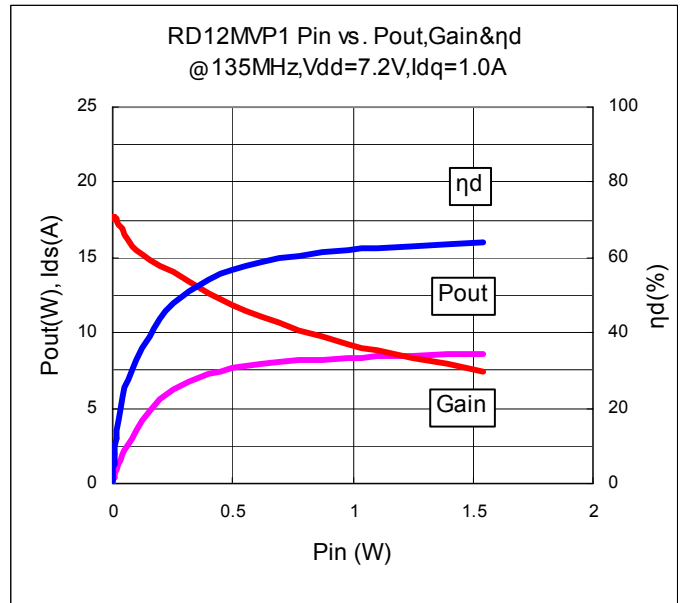
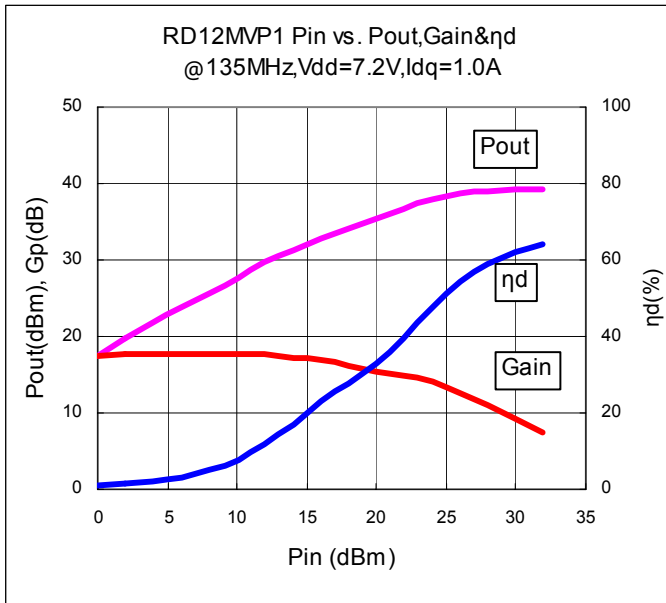

Lot No. 059XA-G

f= 135 MHz

Vdd= 7.2 V

Vgg= 4.77 V

Idq= 1.0 A

Measurement date : 2006/2/10

Pin		Pout		Gp	ID(RF)	ηd	Return Loss.	Harmonics	Harmonics
(dBm)	(W)	(dBm)	(W)	(dB)	(A)	(%)	(dB)	2fo(dBc)	3fo(dBc)
0.0	0.00	17.5	0.06	17.5	1.01	0.78	-1.91	<-60	<-60
2.0	0.00	19.7	0.09	17.8	1.02	1.29	-2.00	<-60	<-60
4.0	0.00	21.7	0.15	17.8	1.02	2.03	-1.95	<-60	<-60
6.0	0.00	23.8	0.24	17.7	1.03	3.21	-1.97	-41.25	<-60
8.1	0.01	25.7	0.37	17.6	1.03	5.01	-2.00	-40.39	<-60
10.1	0.01	27.7	0.59	17.6	1.05	7.83	-1.98	-39.70	<-60
12.0	0.02	29.6	0.92	17.6	1.07	11.89	-1.94	-38.21	<-60
14.1	0.03	31.3	1.34	17.2	1.11	16.77	-2.00	-35.58	<-60
16.0	0.04	32.9	1.97	16.9	1.19	22.97	-2.00	-32.93	<-60
18.0	0.06	34.2	2.63	16.2	1.31	27.76	-2.00	-30.63	-51.62
20.0	0.10	35.4	3.50	15.5	1.48	32.88	-1.98	-28.86	-50.06
22.0	0.16	36.8	4.76	14.8	1.68	39.29	-1.92	-28.22	-49.86
24.0	0.25	38.0	6.30	14.0	1.84	47.66	-1.94	-27.77	-49.58
26.0	0.40	38.7	7.35	12.7	1.88	54.31	-2.08	-27.57	-48.84
27.9	0.62	39.0	7.95	11.1	1.88	58.84	-2.20	-27.41	-48.15
29.9	0.98	39.2	8.36	9.3	1.87	61.98	-2.35	-27.30	-48.92
31.9	1.55	39.4	8.62	7.5	1.87	64.12	-2.44	-27.26	-48.18

RD12MVP1 Pin vs. Pout Characteristics (@ f=155MHz=1.0A)

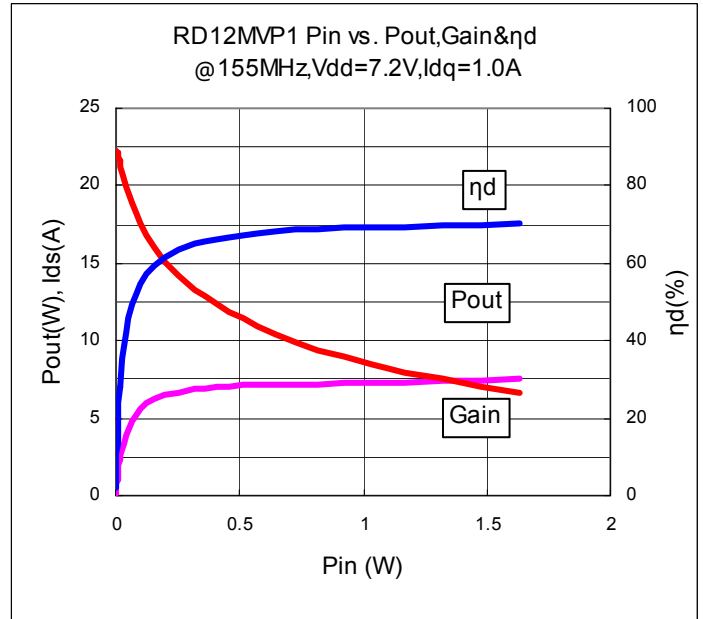
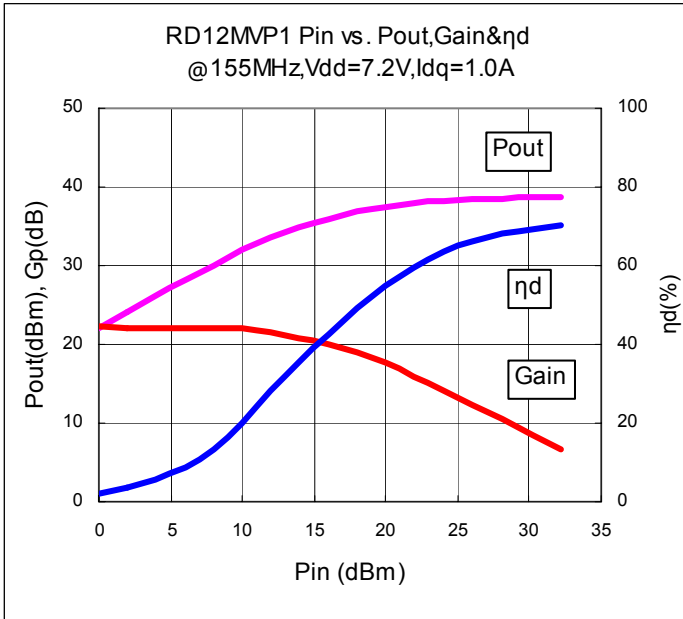

Lot No. 059XA-G  
 f= 155 MHz  
 Vdd= 7.2 V  
 Vgg= 4.77 V  
 Idq= 1.0 A

Measurement date : 2006/2/10

Pin		Pout		Gp	ID(RF)	ηd	Return Loss.	Harmonics	Harmonics
(dBm)	(W)	(dBm)	(W)	(dB)	(A)	(%)	(dB)	2fo(dBc)	3fo(dBc)
0.0	0.00	22.2	0.16	22.2	1.01	2.26	-5.71	<-60	<-60
2.0	0.00	24.1	0.26	22.2	1.02	3.53	-5.73	<-60	<-60
4.0	0.00	26.1	0.41	22.2	1.03	5.55	-5.73	<-60	<-60
6.0	0.00	28.1	0.65	22.1	1.04	8.68	-5.82	-45.98	<-60
8.0	0.01	30.1	1.02	22.1	1.05	13.50	-5.79	-44.81	<-60
10.0	0.01	32.0	1.58	22.0	1.08	20.20	-5.98	-43.18	<-60
12.0	0.02	33.6	2.29	21.6	1.13	28.21	-6.24	-41.29	<-60
14.0	0.02	34.9	3.06	20.9	1.19	35.64	-6.31	-39.20	<-60
16.0	0.04	35.9	3.90	20.0	1.28	42.40	-6.33	-37.53	-53.44
17.9	0.06	36.9	4.87	18.9	1.37	49.31	-6.29	-36.18	-54.56
19.9	0.10	37.5	5.64	17.6	1.43	54.93	-5.97	-35.77	-53.94
22.0	0.16	37.9	6.19	16.0	1.44	59.61	-5.99	-35.40	-53.41
24.0	0.25	38.3	6.69	14.2	1.46	63.71	-6.18	-35.08	-53.69
26.1	0.40	38.4	7.00	12.4	1.47	66.34	-6.42	-34.96	-53.66
28.1	0.65	38.6	7.21	10.5	1.47	68.13	-6.65	-34.82	-53.35
30.2	1.04	38.7	7.35	8.5	1.47	69.29	-6.88	-34.83	-53.21
32.1	1.63	38.7	7.50	6.6	1.48	70.40	-7.08	-34.88	-52.51

RD12MVP1 Pin vs. Pout Characteristics (@ f=175MHz=1.0A)

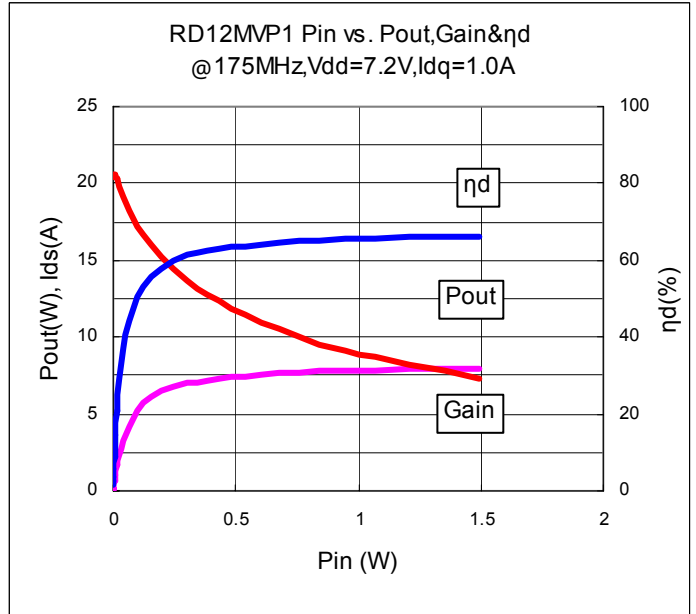
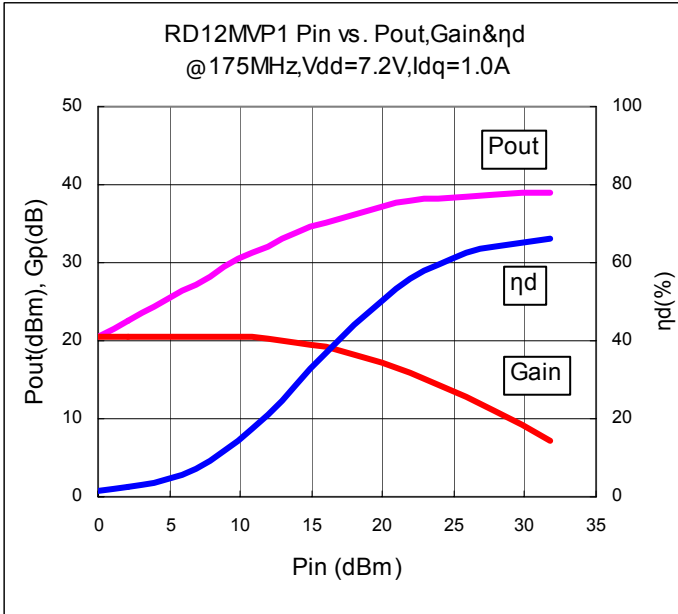

Lot No. 059XA-G

f= 175 MHz

Vdd= 7.2 V

Vgg= 4.77 V

Idq= 1.0 A

Measurement date : 2006/2/10

Pin (dBm)	Pin (W)	Pout (dBm)	Pout (W)	Gp (dB)	ID(RF) (A)	ηd (%)	Return Loss. (dB)	Harmonics 2fo(dBc)	Harmonics 3fo(dBc)
0.0	0.00	20.5	0.11	20.6	1.01	1.55	-10.73	<-60	<-60
2.0	0.00	22.6	0.18	20.6	1.02	2.49	-12.07	<-60	<-60
3.9	0.00	24.4	0.27	20.5	1.02	3.71	-12.09	<-60	<-60
5.9	0.00	26.3	0.43	20.4	1.03	5.79	-10.15	<-60	<-60
7.9	0.01	28.3	0.68	20.4	1.04	9.07	-10.00	<-60	<-60
9.9	0.01	30.4	1.10	20.5	1.06	14.34	-9.81	-48.54	<-60
11.9	0.02	32.2	1.65	20.2	1.10	20.89	-9.40	-47.95	<-60
14.0	0.02	33.8	2.40	19.8	1.15	28.94	-9.03	-46.38	<-60
16.0	0.04	35.1	3.26	19.2	1.23	36.96	-8.75	-44.77	<-60
18.0	0.06	36.2	4.20	18.3	1.32	44.07	-8.59	-43.56	-54.22
19.9	0.10	37.1	5.17	17.2	1.42	50.46	-8.48	-42.78	-54.35
21.9	0.15	37.8	6.06	16.0	1.51	55.78	-8.60	-42.09	-52.18
23.9	0.24	38.3	6.74	14.4	1.57	59.74	-9.10	-41.51	-51.47
25.9	0.39	38.6	7.21	12.7	1.61	62.37	-9.71	-41.35	-51.91
27.8	0.60	38.8	7.53	11.0	1.63	64.11	-10.15	-41.10	-52.02
29.8	0.95	38.9	7.77	9.1	1.65	65.38	-10.41	-40.96	-51.93
31.7	1.49	39.0	7.96	7.3	1.67	66.32	-10.44	-41.02	-51.85

RD12MVP1 Pin vs. Pout Characteristics (@ f=135MHz;Idq=0.7A)

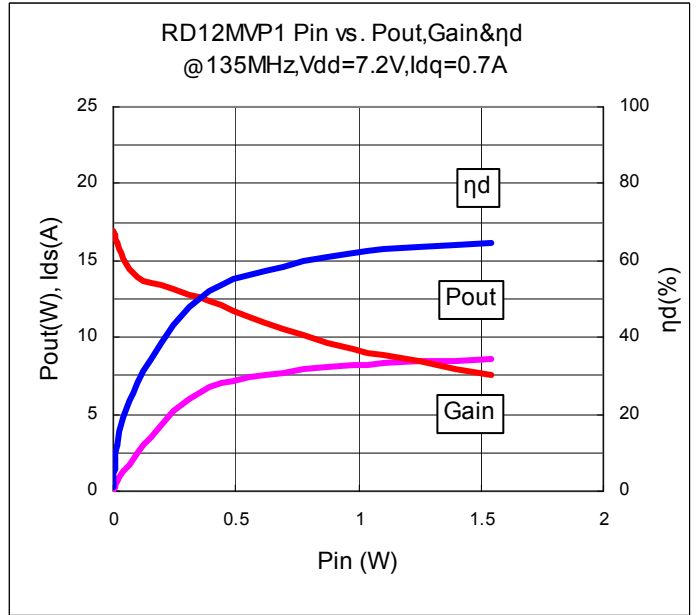
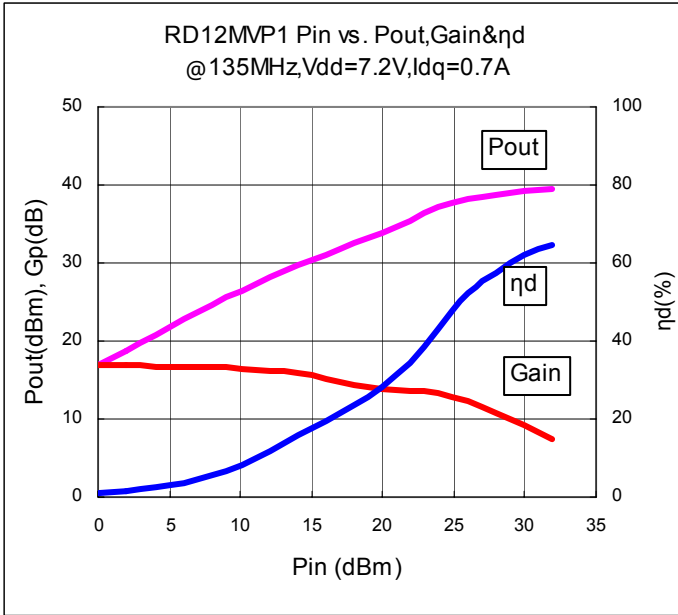

Lot No. 059XA-G

f= 135 MHz

Vdd= 7.2 V

Vgg= 4.77 V

Idq= 0.7 A

Measurement date : 2006/2/10

Pin (dBm)	Pin (W)	Pout (dBm)	Pout (W)	Gp (dB)	ID(RF) (A)	ηd (%)	Return Loss. (dB)	Harmonics 2fo(dBc)	Harmonics 3fo(dBc)
0.0	0.00	16.9	0.05	16.9	0.72	0.95	-1.81	<-60	<-60
2.0	0.00	18.8	0.08	16.9	0.72	1.49	-1.89	<-60	<-60
4.0	0.00	20.8	0.12	16.8	0.72	2.32	-1.85	<-60	<-60
6.1	0.00	22.7	0.19	16.7	0.72	3.59	-1.87	-40.12	<-60
8.1	0.01	24.7	0.29	16.6	0.74	5.54	-1.87	-38.50	<-60
10.1	0.01	26.5	0.45	16.4	0.75	8.28	-1.88	-37.87	<-60
12.1	0.02	28.3	0.67	16.2	0.78	11.91	-1.87	-35.97	<-60
14.0	0.03	29.8	0.95	15.8	0.83	15.82	-1.88	-33.64	<-60
16.0	0.04	31.1	1.29	15.1	0.92	19.52	-1.93	-30.71	<-60
18.0	0.06	32.4	1.76	14.5	1.04	23.39	-1.90	-28.97	-49.57
19.9	0.10	33.9	2.44	14.0	1.21	27.98	-1.92	-27.73	-48.63
21.9	0.16	35.5	3.55	13.6	1.43	34.46	-1.91	-27.21	-47.71
23.9	0.25	37.1	5.17	13.2	1.66	43.17	-1.94	-27.34	-48.64
26.0	0.39	38.3	6.76	12.3	1.80	52.06	-2.08	-27.35	-49.18
27.9	0.62	38.8	7.58	10.9	1.84	57.32	-2.21	-27.21	-48.25
29.9	0.98	39.2	8.27	9.3	1.85	62.07	-2.37	-27.17	-48.29
31.9	1.54	39.4	8.65	7.5	1.86	64.75	-2.45	-27.13	-48.25

RD12MVP1 Pin vs. Pout Characteristics (@ f=155MHz=0.7A)

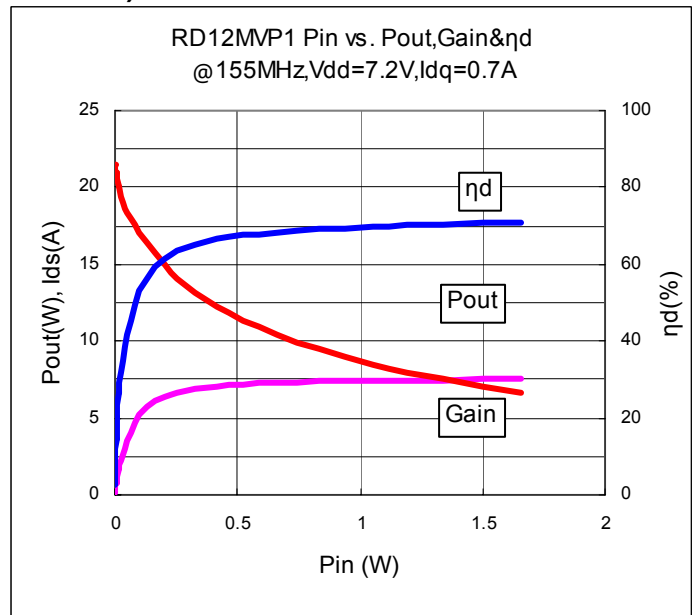
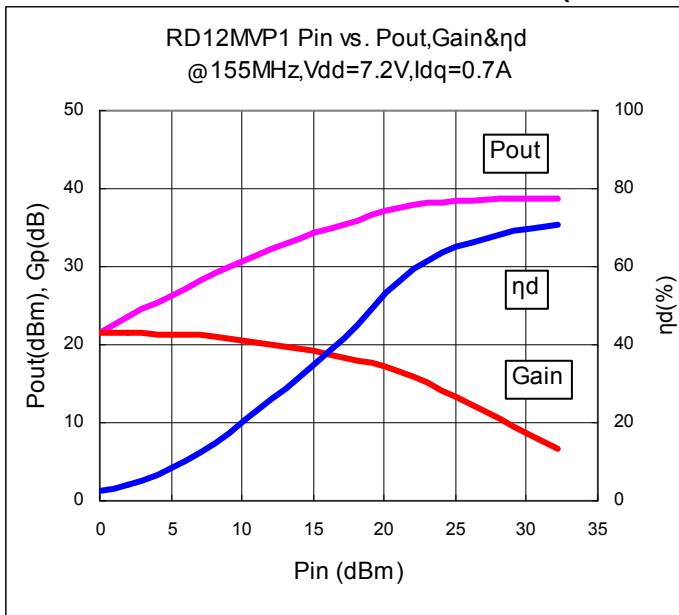

Lot No. 059XA-G

f= 155 MHz

Vdd= 7.2 V

Vgg= 4.77 V

Idq= 0.7 A

Measurement date : 2006/2/10

Pin		Pout		Gp	ID(RF)	ηd	Return Loss.	Harmonics	Harmonics
(dBm)	(W)	(dBm)	(W)	(dB)	(A)	(%)	(dB)	2fo(dBc)	3fo(dBc)
0.0	0.00	21.5	0.14	21.5	0.71	2.76	-5.31	<-60	<-60
2.0	0.00	23.5	0.22	21.4	0.72	4.31	-5.13	<-60	<-60
4.0	0.00	25.4	0.35	21.3	0.73	6.63	-5.09	<-60	<-60
6.1	0.00	27.3	0.54	21.2	0.74	10.07	-5.13	-43.99	<-60
8.1	0.01	29.1	0.81	21.0	0.76	14.80	-5.04	-42.54	<-60
10.1	0.01	30.7	1.19	20.6	0.81	20.43	-5.08	-41.32	<-60
12.2	0.02	32.2	1.66	20.1	0.88	26.31	-5.11	-39.42	<-60
14.1	0.03	33.5	2.24	19.4	0.97	32.02	-5.13	-37.94	<-60
16.2	0.04	34.8	3.01	18.6	1.09	38.32	-5.27	-36.69	<-60
18.1	0.06	36.0	4.00	17.9	1.22	45.37	-5.44	-36.00	<-60
20.1	0.10	37.2	5.20	17.1	1.36	53.14	-5.59	-35.61	-54.14
22.1	0.16	37.9	6.12	15.8	1.43	59.45	-5.73	-35.19	-52.98
24.1	0.26	38.2	6.64	14.1	1.45	63.53	-6.03	-35.05	-53.66
26.2	0.41	38.4	6.99	12.3	1.46	66.41	-6.36	-34.86	-53.01
28.2	0.66	38.6	7.23	10.4	1.47	68.29	-6.61	-34.88	-52.87
30.2	1.05	38.7	7.40	8.5	1.48	69.65	-6.88	-34.76	-52.72
32.2	1.66	38.8	7.55	6.6	1.48	70.70	-7.09	-34.81	-53.09

RD12MVP1 Pin vs. Pout Characteristics (@ f=175MHz=0.7A)

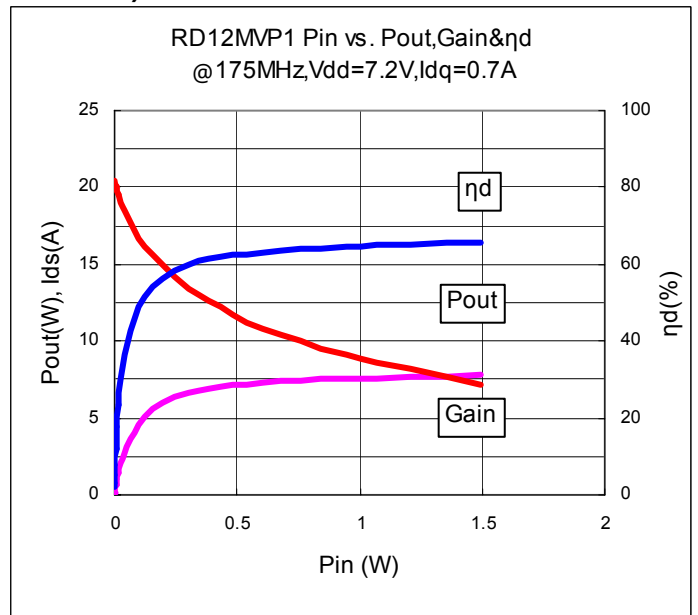
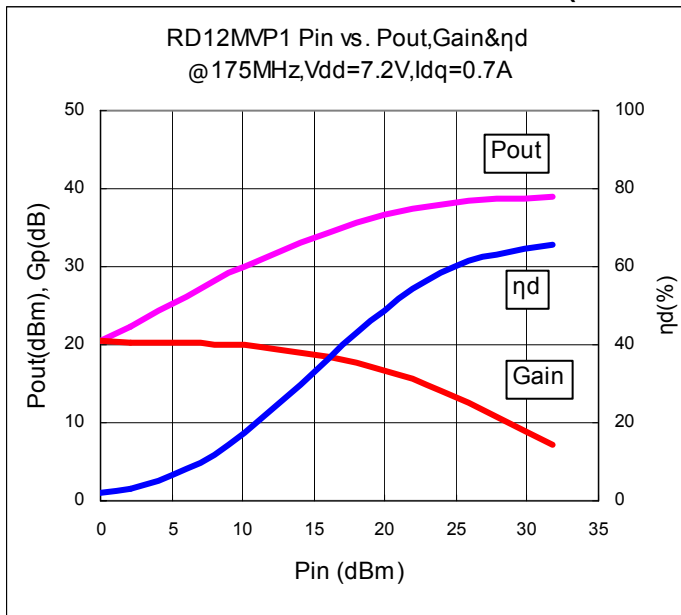

Lot No. 059XA-G

f= 175 MHz

Vdd= 7.2 V

Vgg= 4.77 V

Idq= 0.7 A

Measurement date : 2006/2/10

Pin		Pout		Gp	ID(RF)	$\eta_d$	Return Loss.	Harmonics	Harmonics
(dBm)	(W)	(dBm)	(W)	(dB)	(A)	(%)	(dB)	2fo(dBc)	3fo(dBc)
0.0	0.00	20.4	0.11	20.4	0.71	2.14	-11.60	<-60	<-60
2.0	0.00	22.3	0.17	20.3	0.72	3.30	-12.94	<-60	<-60
4.1	0.00	24.2	0.27	20.2	0.72	5.11	-13.06	<-60	<-60
6.0	0.00	26.2	0.42	20.2	0.73	7.97	-11.07	<-60	<-60
8.1	0.01	28.1	0.65	20.1	0.75	12.02	-11.12	<-60	<-60
10.1	0.01	30.0	0.99	19.9	0.79	17.45	-11.19	-46.59	<-60
12.1	0.02	31.6	1.44	19.5	0.85	23.51	-11.29	-45.11	<-60
14.1	0.03	33.1	2.04	19.0	0.94	29.95	-11.10	-44.12	<-60
16.0	0.04	34.4	2.76	18.5	1.06	36.36	-10.78	-42.97	<-60
18.0	0.06	35.6	3.66	17.6	1.19	42.94	-10.42	-42.44	-52.59
19.9	0.10	36.6	4.62	16.7	1.31	48.88	-9.99	-42.12	-52.48
21.9	0.15	37.5	5.59	15.6	1.43	54.31	-9.72	-41.72	-52.51
23.8	0.24	38.1	6.40	14.2	1.52	58.59	-9.83	-41.63	-51.55
25.8	0.38	38.4	6.97	12.6	1.57	61.46	-10.17	-41.28	-52.35
27.8	0.60	38.7	7.33	10.9	1.61	63.26	-10.42	-41.38	-52.07
29.8	0.94	38.8	7.60	9.1	1.64	64.55	-10.54	-41.31	-52.26
31.7	1.49	38.9	7.82	7.2	1.66	65.60	-10.52	-41.04	-52.13

RD12MVP1 Vdd vs. Pout Characteristics (@ f=135MHz)

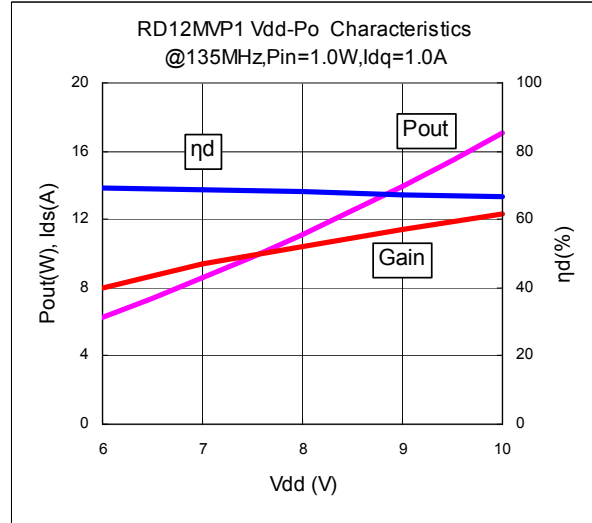
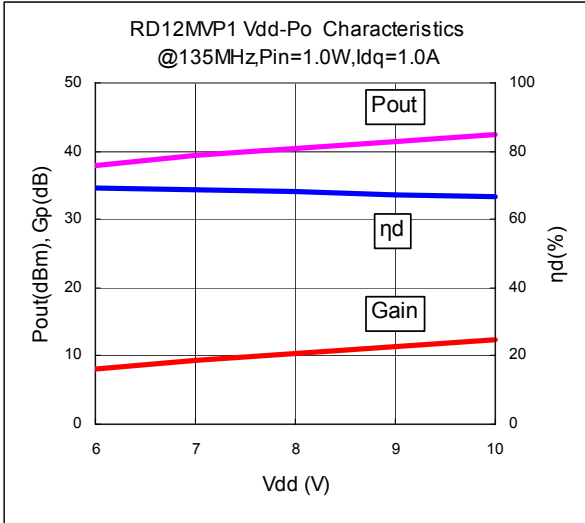

Lot No. 059XA-G

f= 135 MHz

Idq= 1.0 A

Vgg= 4.77 V

Pin= 1.0 W

Measurement date : 2006/2/10

Vdd (V)	Pout		Gp (dB)	ID(RF) (A)	d (%)	Return Loss. (dB)
	(dBm)	(W)				
6.0	38.0	6.28	8.0	1.51	69.24	-1.89
7.0	39.3	8.58	9.4	1.78	68.86	-1.89
8.0	40.5	11.15	10.4	2.05	68.07	-1.89
9.0	41.4	13.96	11.5	2.31	67.19	-1.89
10.0	42.3	17.11	12.3	2.57	66.51	-1.89

RD12MVP1 Vdd vs. Pout Characteristics (@ f=155MHz)

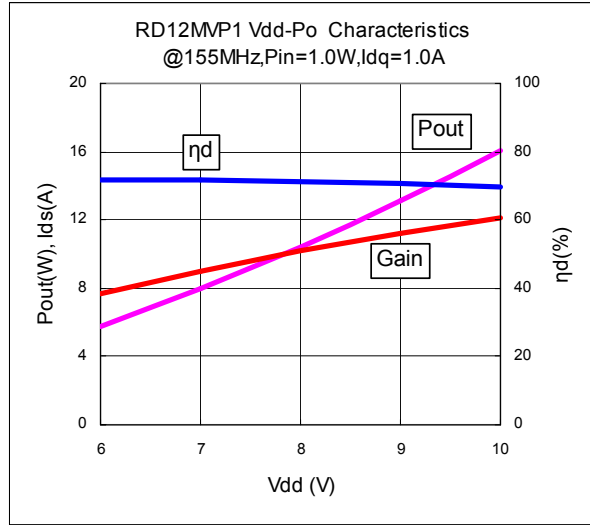
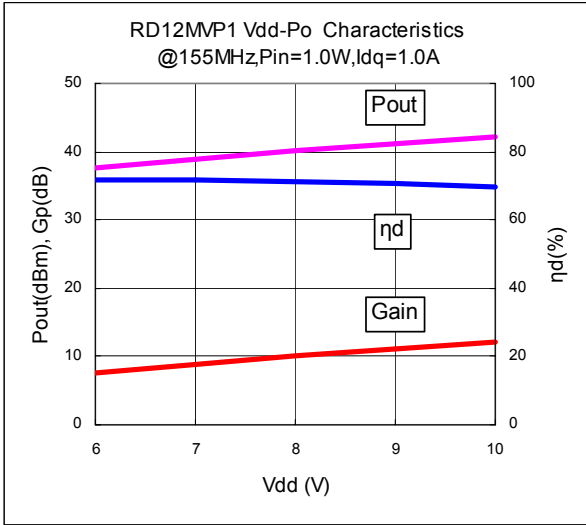

Lot No. 059XA-G

f= 155 MHz  
 Idq= 1.0 A  
 Vgg= 4.77 V  
 Pin= 1.0 W

Measurement day: 2006/2/6

Vdd (V)	Pout		Gp (dB)	ID(RF) (A)	d (%)	Return Loss. (dB)
	(dBm)	(W)				
6.0	37.6	5.77	7.7	1.34	71.92	-6.93
7.0	39.0	7.94	9.0	1.58	71.63	-6.94
8.0	40.2	10.41	10.2	1.83	71.24	-6.92
9.0	41.2	13.16	11.2	2.07	70.74	-6.95
10.0	42.1	16.08	12.1	2.31	69.68	-6.94

RD12MVP1 Vdd vs. Pout Characteristics (@ f=175MHz)

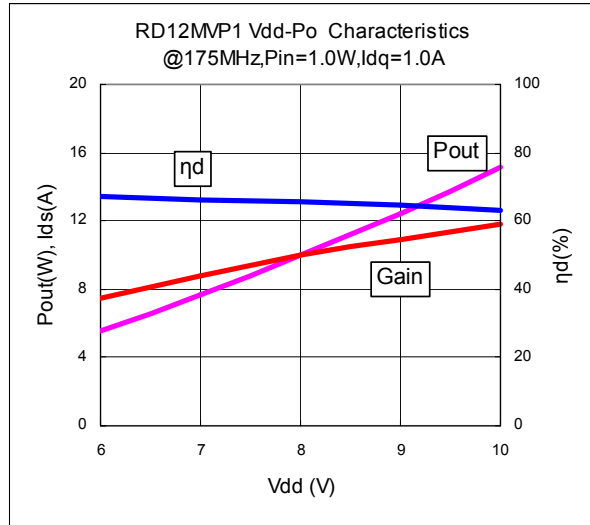
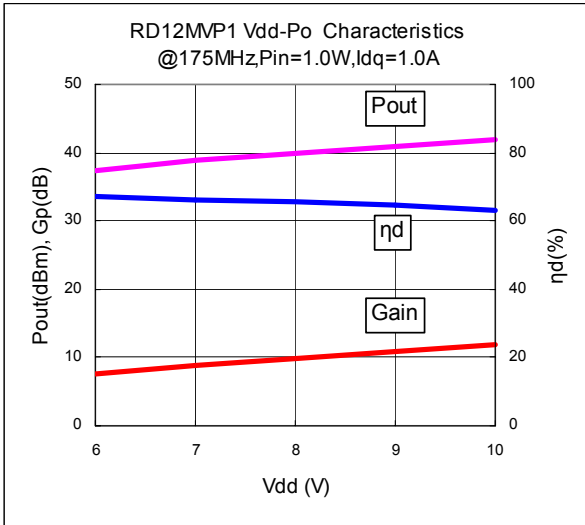

Lot No. 059XA-G

f= 155 MHz

Idq= 1.0 A

Vgg= 4.77 V

Pin= 1.0 W

Measurement day: 2006/2/10

Vdd (V)	Pout		Gp (dB)	ID(RF) (A)	d (%)	Return Loss. (dB)
	(dBm)	(W)				
6.0	37.5	5.59	7.5	1.39	67.00	-8.31
7.0	38.8	7.64	8.8	1.65	66.32	-8.30
8.0	40.0	9.95	10.0	1.90	65.47	-8.32
9.0	41.0	12.47	10.9	2.15	64.59	-8.37
10.0	41.8	15.18	11.8	2.40	63.34	-8.43

RD12MVS1 Equivalent Circuit (f=135 - 175MHz)

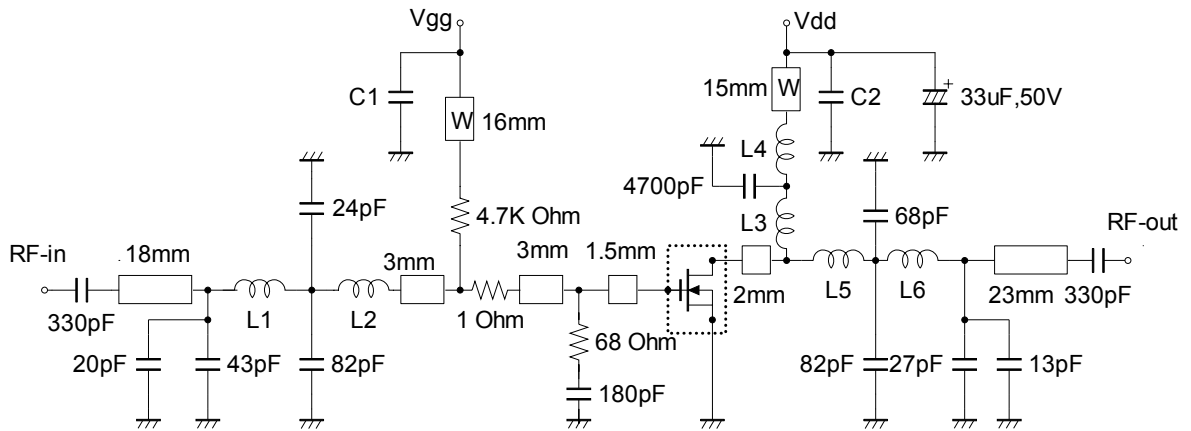

RD12MVP1

Note: Board material= glass-Epoxy Substrate  
 Micro strip line width=1.3mm/50OHM,er=4.8,t=0.8mm  
 W:Line width=1.0mm  
 C1,C2:2200pF

L1:17.2nH,3Turns,D:0.4mm,2.5mm(outside diameter)  
 L2:7.5nH,3Turns,D:0.4mm,1.6mm(outside diameter)  
 L3:6.6nH,2Turns,D:0.23mm,1.6mm(outside diameter)  
 L4:43.7nH,6Turns,D:0.4mm,2.5mm(outside diameter)  
 L5:10.8nH,4Turns,D:0.4mm,1.6mm(outside diameter)  
 L6:37.8nH,7Turns,D:0.23mm,1.6mm(outside diameter)

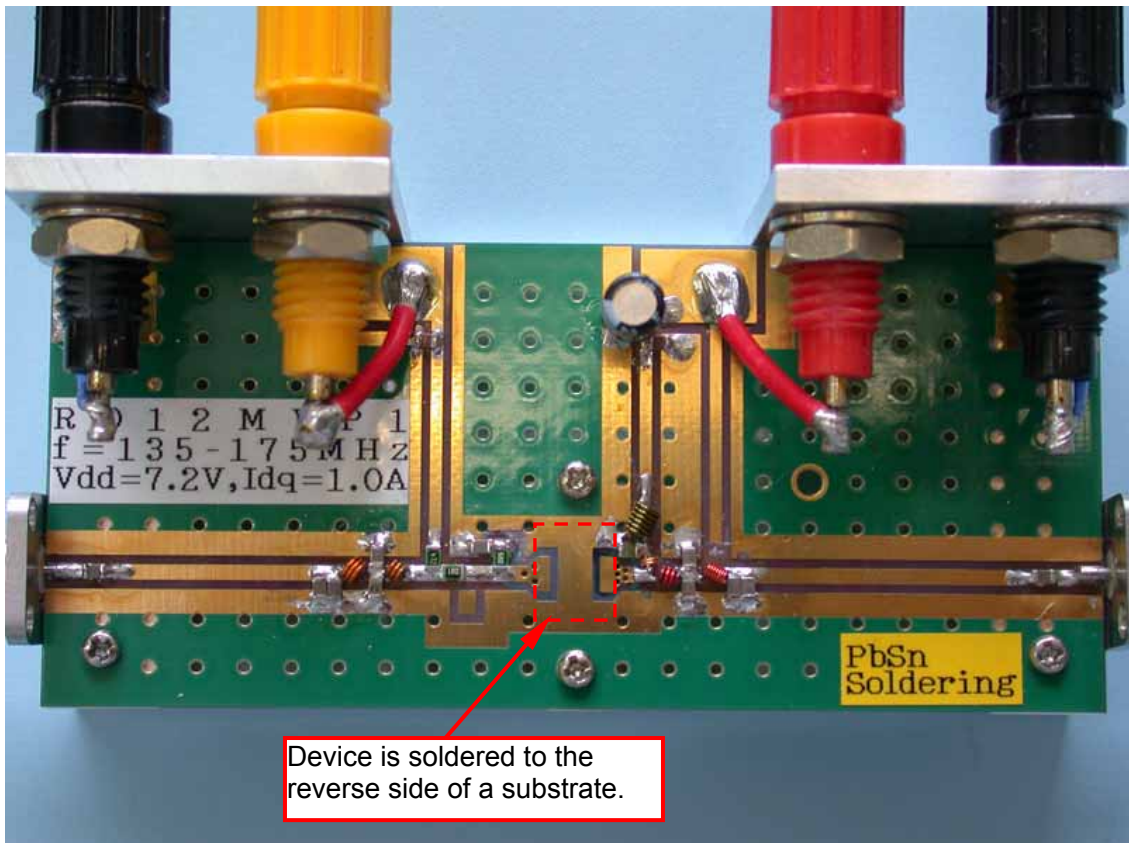

\*RF matching is mediated by a through hole.

Front side View

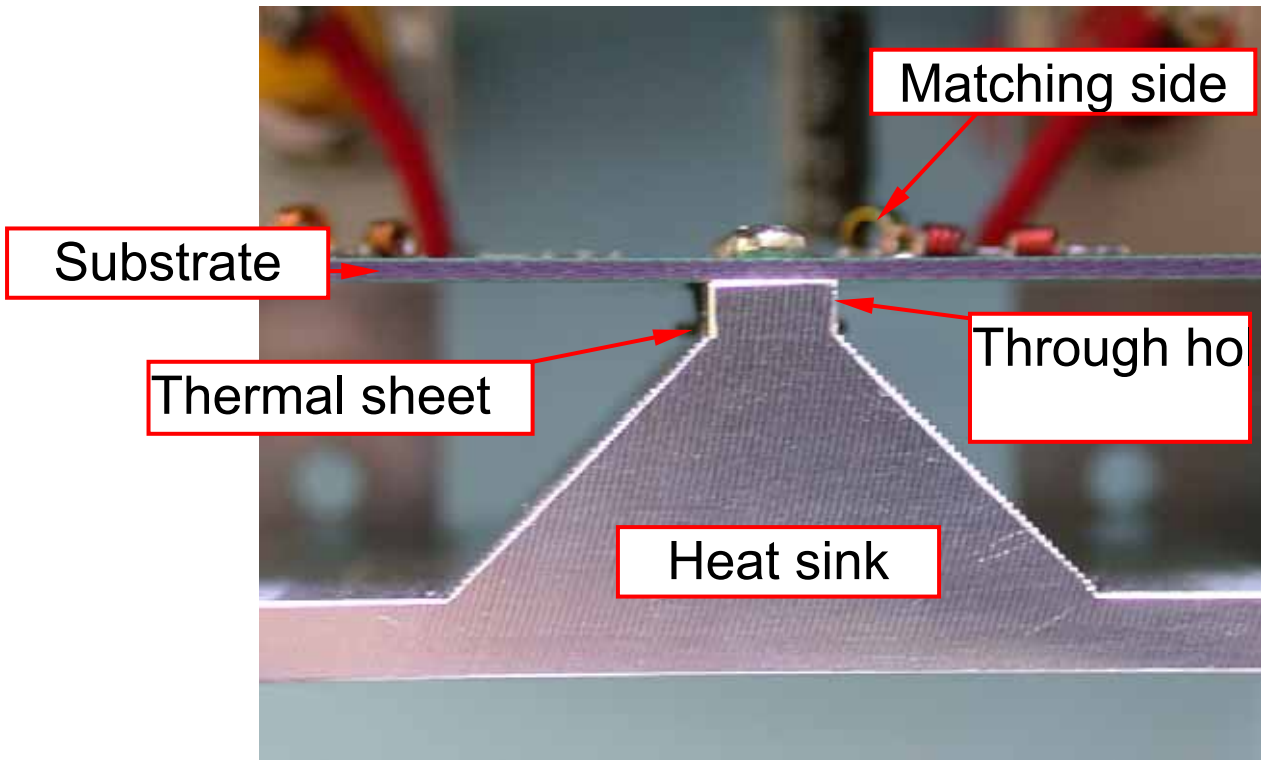

Device contact View

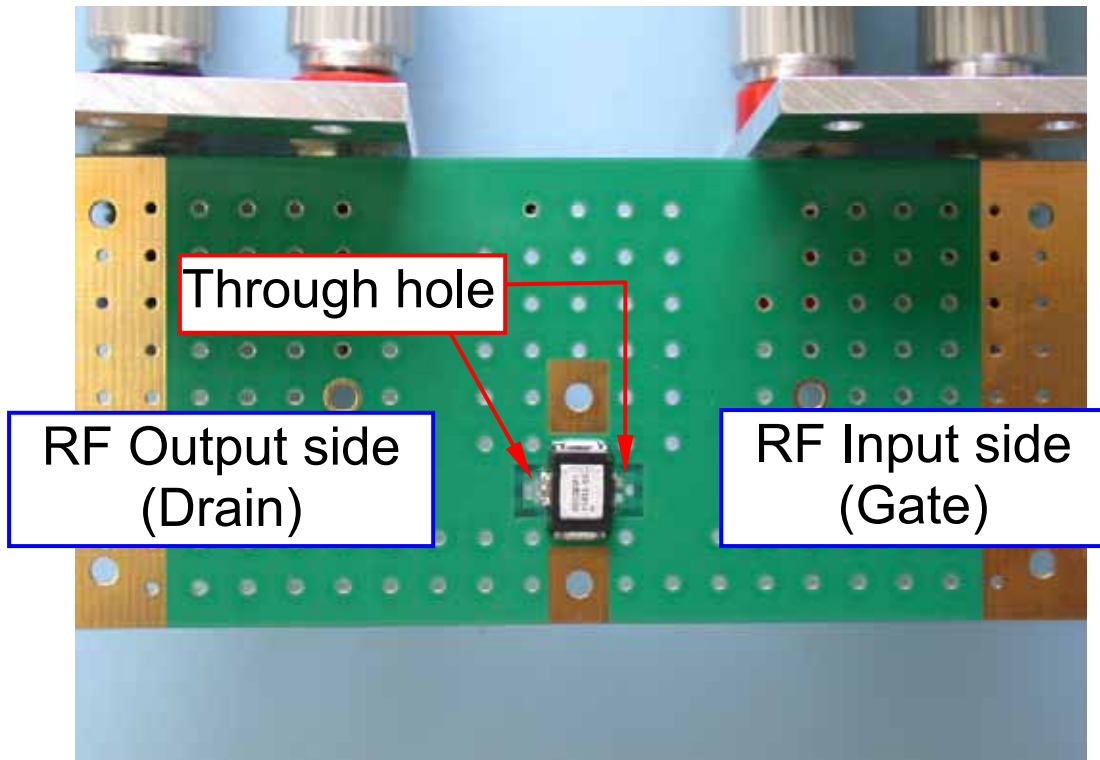

Reverse side View