

How to use Test Fixture for Mitsubishi RF Module

- Top view of Test Fixture -

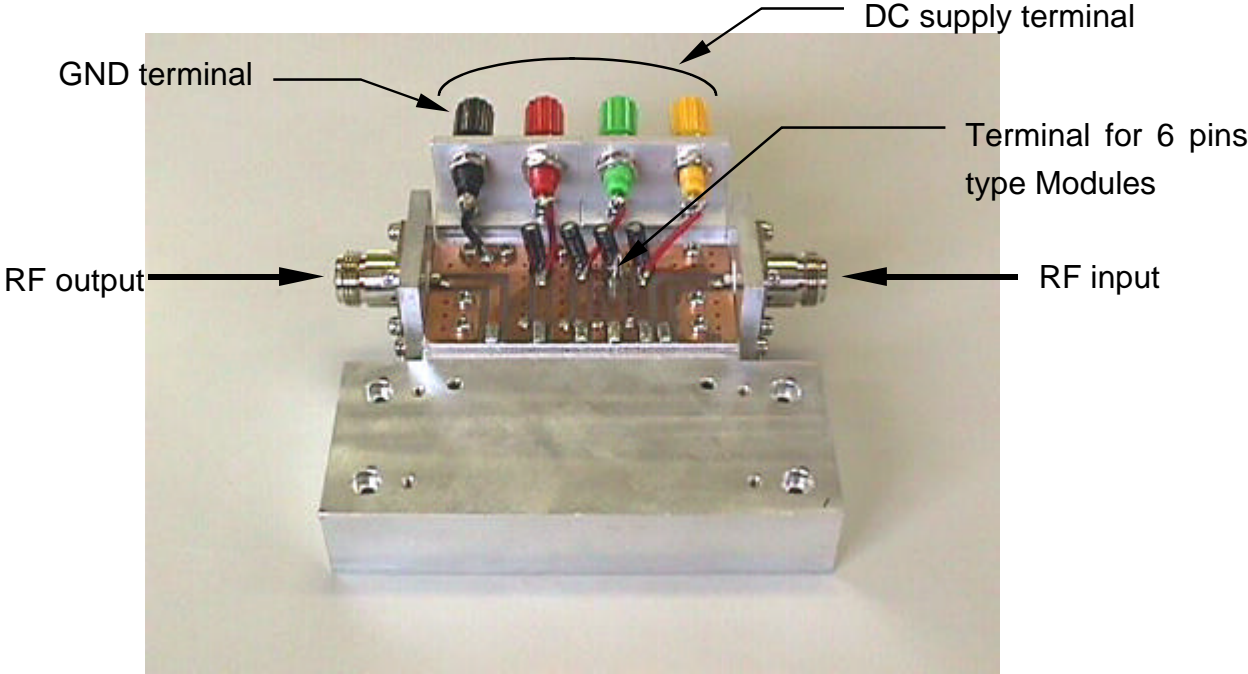

- Top view of Test Fixture with RF Module -

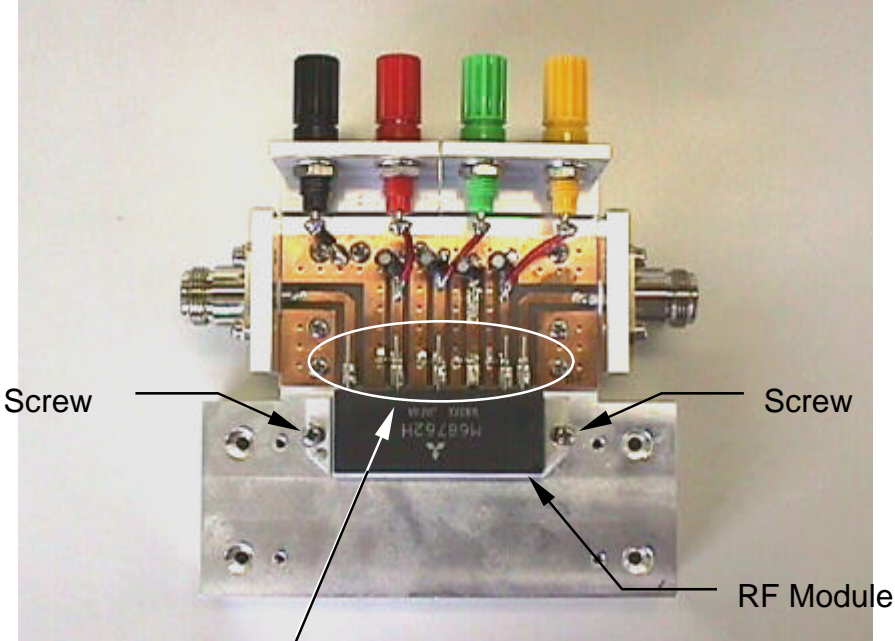

No need soldering to contact pins and lines on the substrate.
We usually push down the pins before mount the Module to get good contact.

- Test Block Diagram (general) -

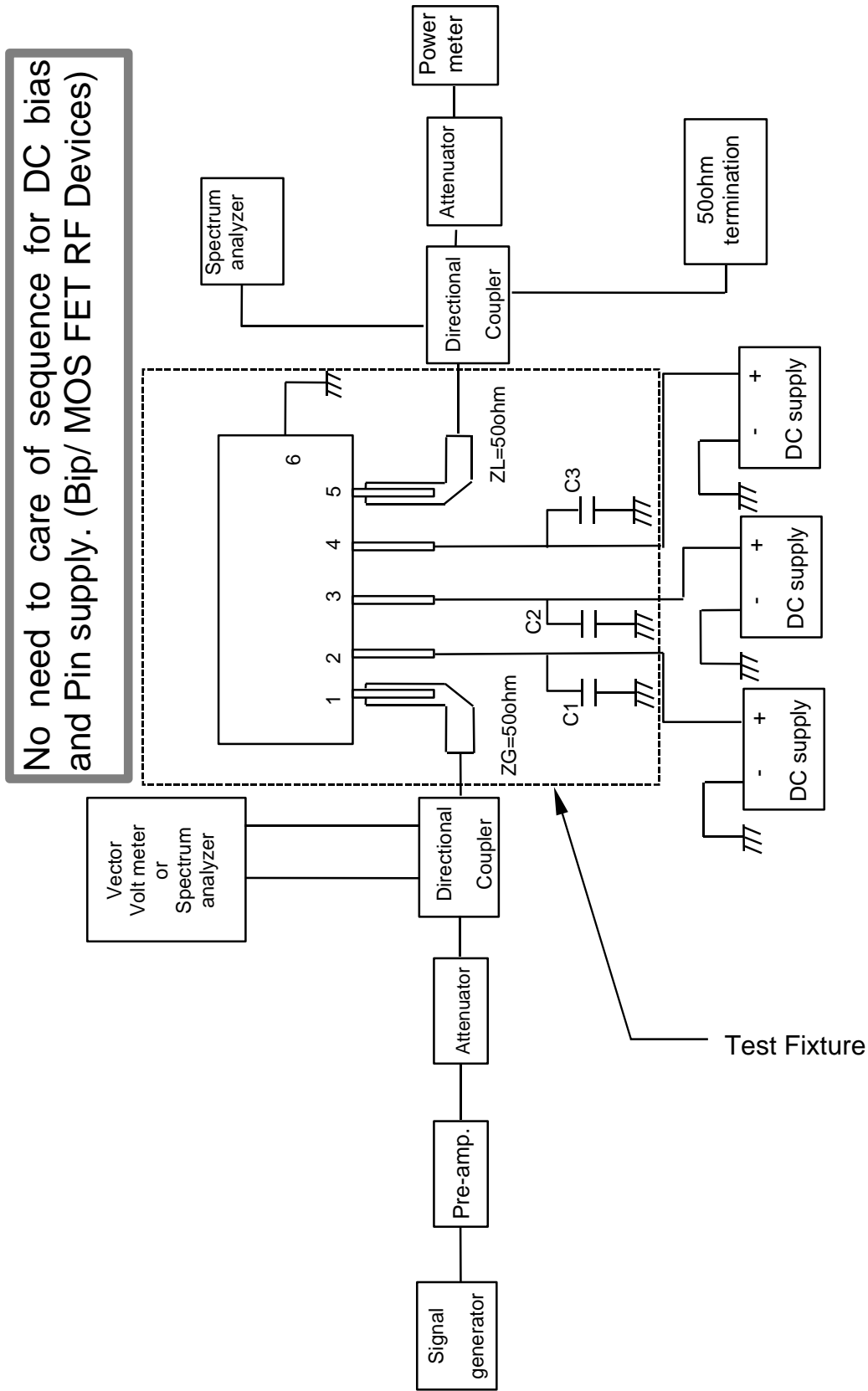

C1,C2,C3: 4700pF, 22uF in pallare!